

VXC/VEX Multi-Port Serial Card User Manual

Version 1.7, Mar 2014



WARRANTY

All products manufactured by ICP DAS are warranted against defective materials for a period of one year from the date of delivery to the original purchaser.

WARNING

ICP DAS assumes no liability for damages consequent to the use of this product. ICP DAS reserves the right to change this manual at any time without notice. The information furnished by ICP DAS is believed to be accurate and reliable. However, no responsibility is assumed by ICP DAS for its use, nor for any infringements of patents or other rights of third parties resulting from its use.

COPYRIGHT

Copyright © 2014 by ICP DAS. All rights are reserved.

TRADEMARK

Names are used for identification only and may be registered trademarks of their respective companies.

CONTACT US

If you have any question, please feel to contact us. We will give you quick response within 2 workdays.

Email: service@icpdas.com, service.icpdas@gmail.com



VXC Series

Board includes

VXC-112A, VXC-112U, VXC-112(i)AU

VXC-114U, VXC-114iAU

VXC-142(i), VXC-142(A)U, VXC-142i(A)U

VXC-144U, VXC-144iU

VXC-182i, VXC-182iAU



VEX Series

Board includes

VEX-112, VEX-112i

VEX-114, VEX-114i

VEX-142, VEX-142i

VEX-144, VEX-144i

Table of Contents

- PACKING LIST.....3
- MORE INFORMATION3
- 1. INTRODUCTION.....4
 - 1.1 FEATURES..... 6
 - 1.2 SPECIFICATIONS 9
 - 1.3 OPTIONS..... 14
- 2. HARDWARE CONFIGURATION 16
 - 2.1 BOARD LAYOUT 16
 - 2.2 SW1 DIP SWITCH (COM PORT MAPPING)..... 18
 - 2.3 WIRING NOTES FOR RS-232/422/485 21
 - 2.4 PIN ASSIGNMENTS 23
- 3. HARDWARE INSTALLATION 27
- 4. SOFTWARE INSTALLATION 31
 - 4.1 OBTAINING THE DRIVER INSTALLER PACKAGE..... 31
 - 4.2 INSTALLING VxCARD DRIVER UNDER WINDOWS 32
 - 4.3 PNP DRIVER INSTALLATION 35
 - 4.4 VERIFYING THE INSTALLATION 37
 - 4.5 CONFIGURATION COM PORT BUFFER SIZE 40
 - 4.6 UNINSTALLING THE DEVICE DRIVER 41
 - 4.7 INSTALLING VxCARD DRIVER UNDER LINUX 42
- 5. TESTING THE VXC/VEX SERIES CARD 45
 - 5.1 VXC/VEX-112/142 SERIES CARD WIRING 45
 - 5.2 VXC-182 SERIES CARD WIRING 47
 - 5.3 VXC/VEX-114/144 SERIES CARD WIRING 48
 - 5.4 SELF-TEST 50
- 6. PROGRAMMING REFERENCE 52
 - 6.1 PCI HARDWARE IDs 52
 - 6.2 I/O ADDRESS MAPPING 53
 - 6.3 UART REGISTER 55
 - 6.4 PROGRAMMABLE BAUD RATE 56
 - 6.5 CUSTOMIZED BAUD RATE 58

Packing List

The shipping package includes the following items:

- One VXC/VEX series Card
- One Quick Start Guide
- One Software Utility CD

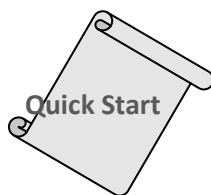

Note:

If any of these items are missing or damaged, please contact the local distributor for more information. Save the shipping materials and cartons in case you need to ship the module in the future.

More Information

Manual/DataSheet/QuickStart:

CD:\NAPDOS\multiport\document

<http://ftp.icpdas.com/pub/cd/iocard/pci/napdos/multiport/document/>

CD:\NAPDOS\multiport>manual

CD:\NAPDOS\multiport>manual\quick_start

<http://ftp.icpdas.com/pub/cd/iocard/pci/napdos/multiport/manual/>

http://ftp.icpdas.com/pub/cd/iocard/pci/napdos/multiport/manual/quick_start/

Software/Drivers:

CD:\NAPDOS\multiport\windows

CD:\NAPDOS\multiport\linux

<http://ftp.icpdas.com/pub/cd/iocard/pci/napdos/multiport/windows/>

<http://ftp.icpdas.com/pub/cd/iocard/pci/napdos/multiport/linux/>

Software/Test2COM/Utility:

CD:\NAPDOS\multiport\utility

<http://ftp.icpdas.com/pub/cd/iocard/pci/napdos/multiport/utility/>

1. Introduction

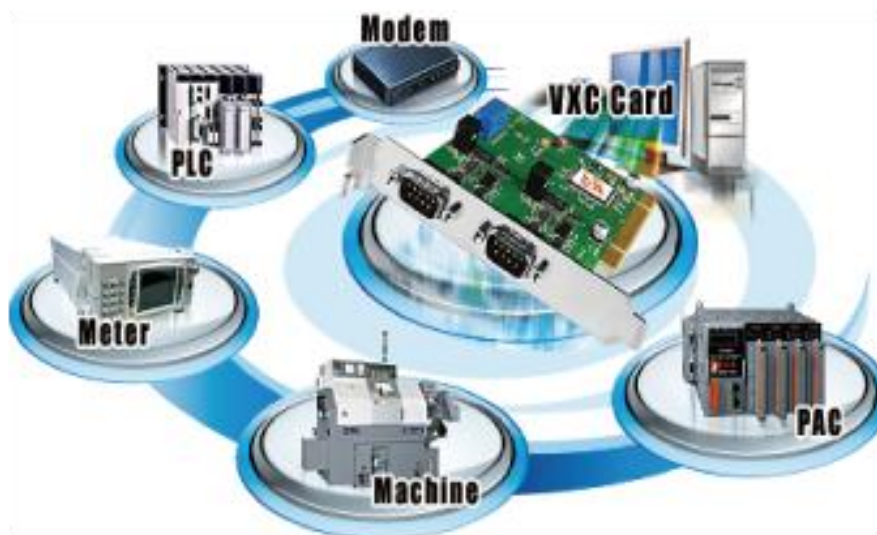

The VXC/VEX multiport serial card enables user to increase additional communication ports on the PC. It's the on-top-of-the-list choice while you are managing to connect lots of outer devices through your PC; every VXC/VEX card ensures you fluent communication in both time-critical applications and industrial fields. With simply a VXC/VEX card, it has never been that easy for integration of a PC with many other devices, like PLCs, FAB machines, meters, controller devices, laboratory instruments, modems, card readers, serial printers, RFID readers, bar code readers, sensors, etc.

■ Comparison Table for VXC/VEX Series Cards:

Model	Bus	RS-232	RS-422/ RS-485	Self-Tuner	Isolation	ESD Protection	FIFO Size (bytes)	Connector
VEX-112	PCI Express	2	-	-	-	-	128	Male DB-9
VEX-112i		2	-	-	2.5 kV	+/- 4 kV	128	Male DB-9
VEX-142		-	2	Yes	-	-	128	Male DB-9
VEX-142i		-	2	Yes	2.5 kV	+/- 4 kV	128	Male DB-9
VEX-114		4	-	-	-	-	128	Female DB-37
VEX-114i		4	-	-	2.5 kV	+/- 4 kV	128	Female DB-37
VEX-144		-	4	Yes	-	-	128	Female DB-37
VEX-144i		-	4	Yes	2.5 kV	+/- 4 kV	128	Female DB-37
VXC-112U	Universal PCI	2	-	-	-	-	128	Male DB-9
VXC-112AU		2	-	-	-	-	128	Male DB-9
VXC-112iAU		2	-	-	2.5 kV	+/- 4 kV	128	Male DB-9
VXC-114U		4	-	-	-	-	128	Female DB-37
VXC-114iAU		4	-	-	2.5 kV	+/- 4 kV	128	Female DB-37
VXC-142U		-	2	Yes	-	-	128	Male DB-9
VXC-142iU		-	2	Yes	2.5 kV	+/- 4 kV	128	Male DB-9
VXC-142AU		-	2	Yes	-	-	128	Male DB-9
VXC-142iAU		-	2	Yes	2.5 kV	+/- 4 kV	128	Male DB-9
VXC-144U		-	4	Yes	-	-	128	Female DB-37
VXC-144iU		-	4	Yes	2.5 kV	+/- 4 kV	128	Female DB-37
VXC-182iU		1	1	Yes	2.5 kV	+/- 4 kV	128	Male DB-9
VXC-182iAU		1	1	Yes	2.5 kV	+/- 4 kV	128	Male DB-9
VXC-112A		PCI Bus	2	-	-	-	-	128
VXC-142	-		2	Yes	-	-	128	Male DB-9
VXC-142i	-		2	Yes	2.5 kV	+/- 4 kV	128	Male DB-9
VXC-182i	1		1	Yes	2.5 kV	+/- 4 kV	128	Male DB-9

1.1 Features

PCI Express

PCI Express (PCIe) is a computer expansion card standard. A key difference between PCIe and earlier PC buses is a topology based on point-to-point serial links, rather than shared parallel bus architecture. Conceptually, the PCIe bus can be thought of as a 'high-speed serial replacement' of the older PCI/PCI-X bus.



Universal PCI (3.3 V and 5 V)

The Universal PCI card works with both the newer 3.3 V PCI bus that is widely-used in servers, and the traditional 5 V PCI bus. The Universal PCI interface will be the standard for every card developed by ICP DAS in the near future.

COM-Selector

Each VXC/VEX card is equipped with a COM-Selector (Dip Switch) for the COM port number selection (automatically or manually). It's an important and innovative feature for the VXC/VEX family.



Easy COM Port Selection by DIP switch

The COM-Selector provides the following advantages:

- Simplifies the COM port number selection instead of using configuration utility programs.
- Users can specify the COM port number of the VXC/VEX card as exactly what they want, no matter which PCI slot it is located at.
- Automatically select an available COM port number is supported by setting the COM-Selector (dip switch) to 0 (default).
- No need to install configuration utility and to study its operation for different OS. Prevents confusion. Other PnP COM port devices easily confuse users because of adopting the dynamic COM port number setting.
- Easy replacement of an existing card by setting the dip-switch to be the same COM port number.
- Great for mass system installation, since setting the dip-switch to be the same COM port number is very easy.

ESD Protection

The VXC/VEX cards offer TVS diode ESD protection technology, protecting your system from being damaged by the high potential voltages.

Under normal operating conditions, the TVS diode presents high impedance (appears as an open circuit) to the protected component. When the voltage is beyond the limits, the TVS diode avalanches providing a low impedance path for the transient current. As a result, the transient current is diverted away from the protected components and shunted through the TVS diode. The device returns to a high impedance state after the transient threat passes.

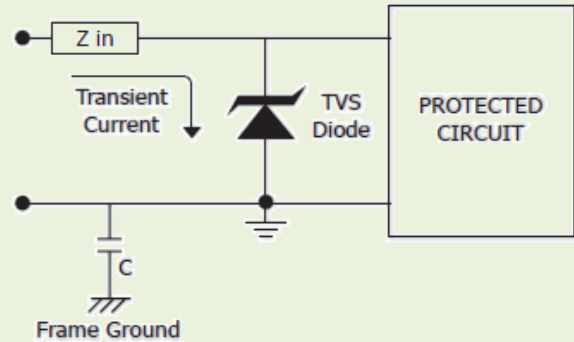

Hardware FIFO up To 128 Bytes

The VXC/VEX cards offer TVS diode ESD protection technology, protecting your system from being damaged by the high potential voltages.

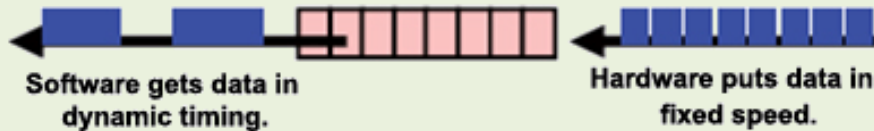

VXC/VEX series cards are equipped with a large 16-byte or 128-byte hardware FIFO for each port. A large hardware FIFO is useful for preventing data loss if the loading on your system is heavy, e.g. while you are running a multi-task operating system, such as Windows, or Linux, etc.

Up To 128 KB COM Port Buffer

The VXC/VEX card driver for Windows features a 128 KB maximum software FIFO for each port (default is 4 KB). It's practical for large file transmission.

Self-Tuner

The VXC/VEX series cards are equipped with an internal “Self-Tuner” chip that is used to automatically control the direction of the transmission and receiving of signals on the RS-485 ports.

Without the inclusion of the Self-Tuner, the RS-485 transmitter would need to be manually enabled before transmitting, and then disabled once the transmission is complete. The timing method that is used to enable and disable the transmitter (direction control) is a major source of many communication problems, and is very difficult to rectify.

The built-in Self-Tuner embedded on the VXC/VEX series cards can help effectively eliminate any issues related to direction control and also simplifies the software programming required for communication applications.

Isolation

Some VXC/VEX cards offer photo isolation to protect your computer and equipment against damages in harsh environment.

Photo coupler is a device that uses a short optical transmission path to transfer a signal between elements of a circuit, typically a transmitter and a receiver. This keeping them electrically isolated — since the signal goes from an electrical signal to an optical signal, the electrical contact along the path is broken.

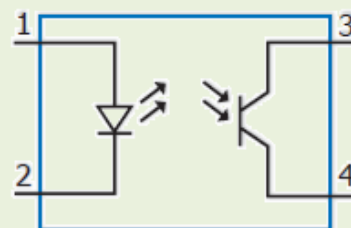

Photo Coupler Operation

It can help cutting down on ground loops, common mode voltages and block voltage spikes, provide electrical isolation, and offer significant protection from serious over-voltage conditions in one circuit affecting the other.

Various Accessories

There are a lot of optional accessories for the VXC/VEX series cards, such as RS-232 cables and daughter boards. These tools make wiring much easily than ever.

1.2 Specifications

1.2.1 VXC/VEX-112 Series

Models	VXC-112A	VXC-112U VXC-112AU	VXC-112iAU	VEX-112	VEX-112i
Communication Port					
COM1 - COM2	RS-232 (TxD, RxD, RTS, CTS, DTR, DSR, DCD, RI, GND)				
UART	16c550 compatible	16c950 compatible			
Baud Rate	50 - 115200 bps				
Data Bits	5, 6, 7, 8				
Stop Bits	1, 1.5, 2				
Parity	None, Even, Odd, Mark, Space				
FIFO	Internal 16 bytes	Internal 128 bytes			
Isolated	-	-	2500 V _{DC}	-	2500 V _{DC}
General					
Bus Type	PCI, 5 V, 33 MHz, 32-bit, Plug and Play	Universal PCI, 3.3 V/5 V, 33 MHz, 32-bit, Plug and Play		PCI Express x1, Plug and Play	
COM-Selector	Yes (8-bit DIP Switch)				
Connector	2 x DB9 (Male)				
Power Consumption	105 mA @ 5 V	100 mA @ 5 V	480 mA @ 5 V	120 mA @ 5 V	440 mA @ 5 V
Operating Temperature	0°C ~ +60°C				
Storage Temperature	-20°C ~ +70°C				
Humidity	0 ~ 90% RH, non-condensing				
Dimensions (L x W x D)	130 mm x 105 mm x 22 mm	134 mm x 90 mm x 22 mm		110 mm x 94 mm x 22 mm	

1.2.2 VXC/VEX-114 Series

Models	VXC-114U	VXC-114iAU	VEX-114	VEX-114i
Communication Port				
COM1 - COM4	RS-232 (TxD, RxD, RTS, CTS, DTR, DSR, DCD, RI, GND)			
UART	16c950 compatible			
Baud Rate	50 ~ 115200 bps			
Data Bits	5, 6, 7, 8			
Stop Bits	1, 1.5, 2			
Parity	None, Even, Odd, Mark, Space			
FIFO	Internal 128 bytes			
Isolated	-	2500 V _{DC}	-	-2500 V _{DC}
General				
Bus Type	Universal PCI, 3.3 V/5 V, 33 MHz, 32-bit, Plug and Play		PCI Express x1, Plug and Play	
COM-Selector	Yes (8-bit DIP Switch)			
Connector	DB-37 (Female)			
Power Consumption	120 mA @ 5 V	880 mA @ 5 V	120 mA @ 5 V	880 mA @ 5 V
Operating Temperature	0°C ~ +60°C			
Storage Temperature	-20°C ~ +70°C			
Humidity	0 ~ 90% RH, non-condensing			
Dimensions (L x W x D)	142 mm x 84 mm x 22 mm	133 mm x 93 mm x 22 mm	110 mm x 110 mm x 22 mm	

1.2.3 VXC/VEX-142 Series

Models		VXC-142	VXC-142i	VXC-142U VXC-142AU	VXC-142iU VXC-142iAU	VEX-142	VEX-142i
Communication Port							
COM1- COM2	RS-422/485		The RS-422 and RS-485 interfaces cannot be used simultaneously.				
	RS-422		RS-422 (TxD+, TxD-, RxD+, RxD-, RTS+, RTS-, CTS+, CTS-, GND)				
	RS-485	2-Wire	RS-485 (Data+, Data-, GND)				
		Bias Resistor	Yes, 1 K Ω				
		Nodes	256 (max.)				
UART		16c550 compatible		16c950 compatible			
Baud Rate		50 ~ 115200 bps					
Data Bits		5, 6, 7, 8					
Stop Bits		1, 1.5, 2					
Parity		None, Even, Odd, Mark, Space					
FIFO		Internal 16 bytes		Internal 128 bytes			
Isolated		-	3000 V _{DC}	-	2500 V _{DC}		2500 V _{DC}
General							
Bus Type		PCI, 5 V, 33 MHz, 32-bit, Plug and Play		Universal PCI, 3.3 V/5 V, 33 MHz, 32-bit, Plug and Play		PCI Express x1, Plug and Play	
COM-Selector		Yes (8-bit DIP Switch)					
Connector		2 x DB9 (Male)					
Power Consumption		105 mA @ 5 V	500 mA @ 5 V	100 mA @ 5 V	480 mA @ 5 V	120 mA @ 5 V	440 mA @ 5 V
Operating Temperature		0°C ~ +60°C					
Storage Temperature		-20°C ~ +70°C					
Humidity		0 ~ 90% RH, non-condensing					
Dimensions (L x W x D)		130 mm x 105 mm x 22 mm	140 mm x 95 mm x 22 mm	134 mm x 90 mm x 22 mm		110 mm x 94 mm x 22 mm	

1.2.4 VXC/VEX-144 Series

Models		VXC-144U	VXC-144iAU	VEX-144	VEX-144i
Communication Port					
COM1- COM4	RS-422/485		The RS-422 and RS-485 interfaces cannot be used simultaneously.		
	RS-422		RS-422 (TxD+, TxD-, RxD+, RxD-, RTS+, RTS-, CTS+, CTS-, GND)		
	RS-485	2-Wire	RS-485 (Data+, Data-, GND)		
		Bias Resistor	Yes, 1 K Ω		
	Nodes	256 (max.)			
UART		16c950 compatible			
Baud Rate		50 ~ 115200 bps			
Data Bits		5, 6, 7, 8			
Stop Bits		1, 1.5, 2			
Parity		None, Even, Odd, Mark, Space			
FIFO		Internal 128 bytes			
Isolated		-	2500 V _{DC}	-	-2500 V _{DC}
General					
Bus Type		Universal PCI, 3.3 V/5 V, 33 MHz, 32-bit, Plug and Play		PCI Express x1, Plug and Play	
COM-Selector		Yes (8-bit DIP Switch)			
Connector		DB-37 (Female)			
Power Consumption		120 mA @ 5 V	880 mA @ 5 V	120 mA @ 5 V	880 mA @ 5 V
Operating Temperature		0°C ~ +60°C			
Storage Temperature		-20°C ~ +70°C			
Humidity		0 ~ 90% RH, non-condensing			
Dimensions (L x W x D)		142 mm x 84 mm x 22 mm	142 mm x 95 mm x 22 mm	114 mm x 101 mm x 22 mm	

1.2.5 VXC-182 Series

Models		VXC-182i	VXC-182iU VXC-182iAU
Communication Port			
COM1	RS-422/485		The RS-422 and RS-485 interfaces cannot be used simultaneously.
	RS-422		RS-422 (TxD+, TxD-, RxD+, RxD-, RTS+, RTS-, CTS+, CTS-, GND)
	RS-485	2-Wire	RS-485 (Data+, Data-, GND)
		Bias Resistor	Yes, 1 K Ω
	Nodes	256 (max.)	
COM2		RS-232 (TxD, RxD, RTS, CTS, DTR, DSR, DCD, RI, GND)	
UART		16c950 compatible	
Baud Rate		50 ~ 115200 bps	
Data Bits		5, 6, 7, 8	
Stop Bits		1, 1.5, 2	
Parity		None, Even, Odd, Mark, Space	
FIFO		Internal 128 bytes	
Isolated		2500 V _{DC} for RS-422/485 port	
General			
Bus Type		PCI, 5 V, 33 MHz, 32-bit, Plug and Play	Universal PCI, 3.3 V/5 V, 33 MHz, 32-bit, Plug and Play
COM-Selector		Yes (8-bit DIP Switch)	
Connector		2 x DB9 (Male)	
Power Consumption		200 mA @ 5 V	
Operating Temperature		0°C ~ +60°C	
Storage Temperature		-20°C ~ +70°C	
Humidity		0 ~ 90% RH, non-condensing	
Dimensions (L x W x D)		134 mm x 90 mm x 22 mm	

1.3 Options

Item & Description	VXC-112 series	VXC-182 series	VXC-142 series	VEX-112 series	VEX-142 series
 CA-PC09F 9-pin Female D-sub connector with plastic cover	✓	✓	✓	✓	✓
 DN-09-2/ DN-09-2F I/O Connector Block with DIN-Rail Mounting and two 9-Pin male Header	✓	✓	✓	✓	✓
 CA-0910F 9-pin Female-Female D-sub Cable, 1 m	✓	✓	✓	✓	✓
 CA-0910N 9-pin Female-Female D-sub Cable, 1 m Null Modem Cable	✓	✓	✓	-	-
 CA-0915 9-pin Male-Female D-sub Cable, 1.5 m	✓	✓	✓	✓	✓
 CA-090910 9-pin Female D-sub & (9-wire) RS-422 Cable, 1 m	-	✓	✓	-	✓
 CA-0903 9-pin Female D-sub & 5-wire RS-232 Cable, 30 cm	✓	✓	-	-	-
 CA-0910 9-pin Female D-sub & 3-wire RS-232 Cable, 1 m	✓	✓	-	-	-

Item & Description	VXC-114(iA)U VEX-114(i)	VXC-144(i)U VEX-144(i)
 <p>CA-4002 37-pin Male D-sub connector with plastic cover</p>	✓	✓
 <p>DN-37 I/O Connector Block (Pitch= 5.08 mm) with DIN-Rail Mounting Include: One CA-3710 (37-pin Male-Male D-sub Cable 1.0 m)</p>	✓	✓
 <p>CA-3710 37-Pin Male-Male D-sub Cable 1 m (45°)</p>	✓	✓
 <p>CA-3710D 37-Pin Male-Male D-sub Cable 1 m (180°)</p>	✓	✓
 <p>CA-3720 DB-37 Male-Male D-sub Cable 2 m Cable(45 °)</p>	✓	✓
 <p>CA-3720D 37-Pin Male-Male D-sub Cable 2 m (180°)</p>	✓	✓
 <p>CA-9-3715D DB-37 Male(D-sub) to 4-Port DB-9 Male(D-sub) Cable 1.5 M (180 °)</p>	✓	✓

2. Hardware Configuration

2.1 Board Layout

■ VXC-114/144 series:

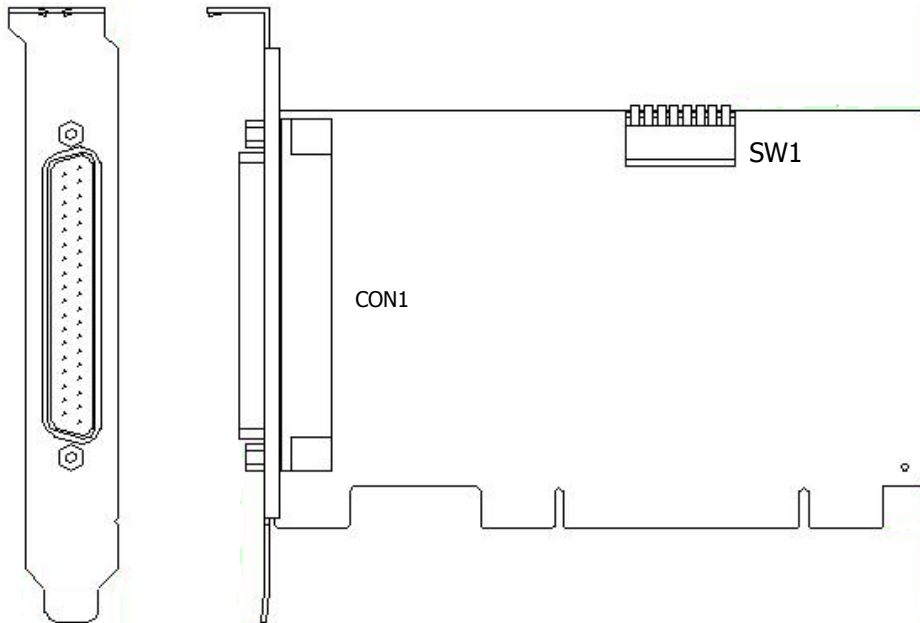

■ VXC-112/142/182 series:

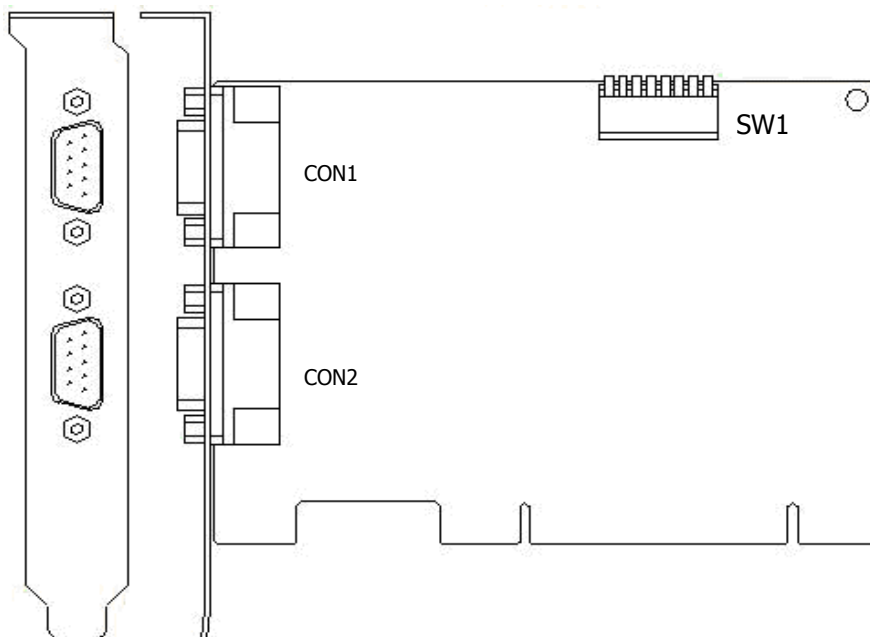

■ VEX-114/144 series:

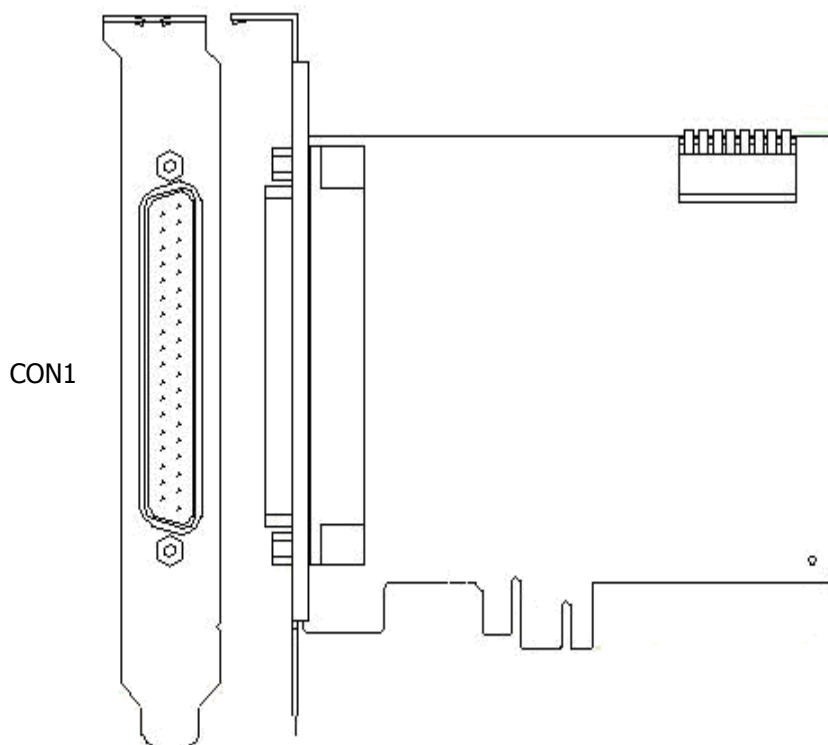

■ VEX-112/142 series:

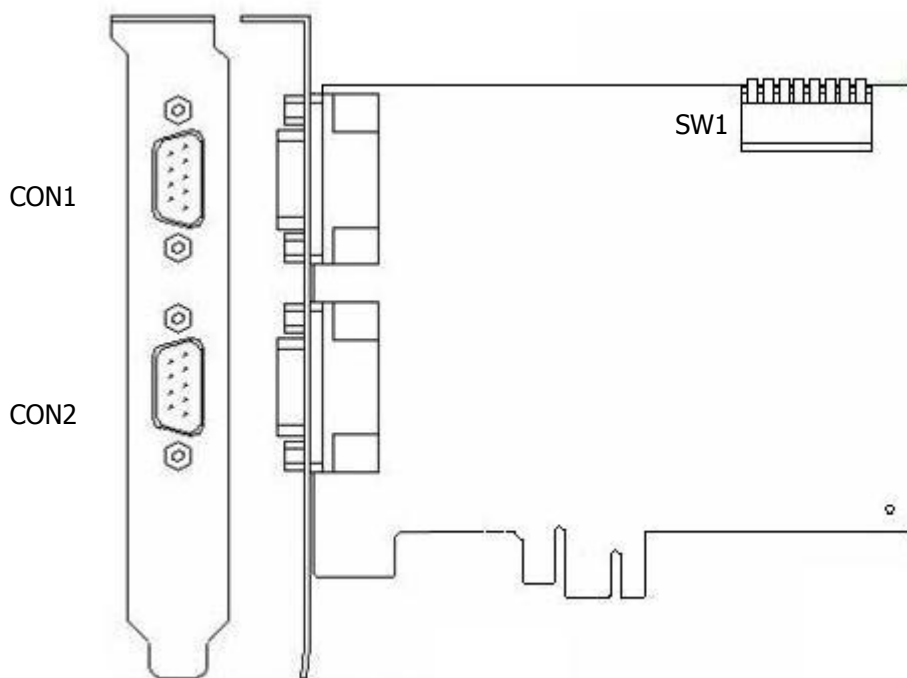

2.2 SW1 DIP Switch (COM Port Mapping)

The Board ID and COM port mapping are the same, which is set by the **SW1 DIP Switch**. The **SW1 DIP Switch** has different functions under different OS.

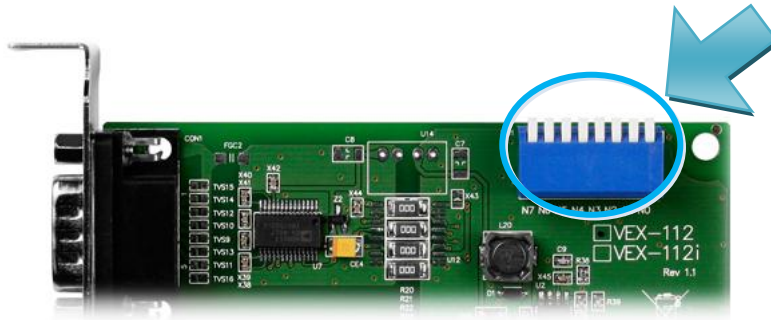

For **DOS** users, the SW1 DIP switch acts as **Board ID**. When there are two or more multi-port serial cards in a single system, it is difficult to identify individual card number. For easier identification, the VXC/VEX series card includes a Board ID function.

For **Windows** users, the SW1 DIP switch acts as **COM port number selector** and the COM port number is depending on the Board ID. If the Board ID is 0, then the driver finds a valid number for each port. If the Board ID is not 0, then the driver uses the “**Board ID**” to be the first COM port number and uses the “**Board ID +1**” to be the next COM port number and so on.

For **Linux** users, it's the same as Windows users but for **TTY device number selector**.



Note:

It's recommended to select a unique COM port number (Board ID) by users. This helps users to clear identify and fix the card-number and port-number in a system.

Warning:

The port will not work if the COM port number is conflicted under Windows or Linux system. In that case, users should try other COM port numbers.

Usually, the COM1 and COM2 are reserved by systems. And it's recommended to reserve the COM3 and COM4 if you will have other Plug&Play serial ports in the future. This prevents conflict.

2.2.1 VXC/VEX-112/142/182 Series cards

The COM port mapping configuration examples are as follows:

If Setting SW1 dip-switch (COM Selector) to **0x05** (1 and 3 “NO→1”, others “OFF→0”).The setting forces the **2-port** VXC/VEX series card to use **COM5 and COM6**.

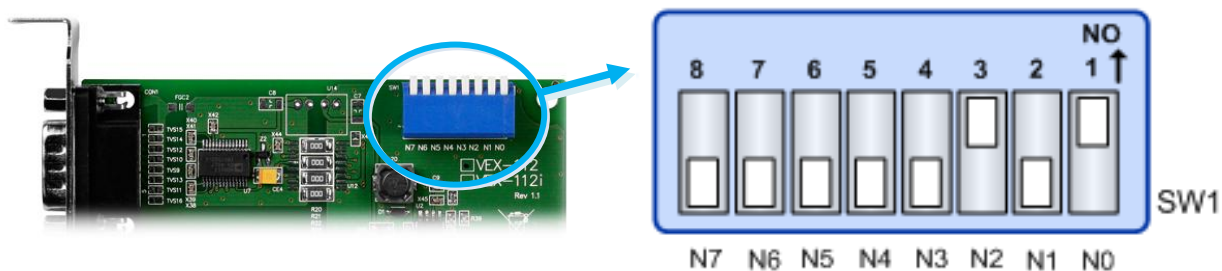

■ SW1 Setting Table for the VXC/VEX-112/142/182 Series (2-Port):

SW1 DIP Switch	8	7	6	5	4	3	2	1
Board ID= 0x00 (Default) COM = Auto-defined	OFF	OFF	OFF	OFF	OFF	OFF	OFF	OFF
Bard ID= 0x03 COM= 3/4	OFF	OFF	OFF	OFF	OFF	OFF	ON	ON
Bard ID= 0x05 COM= 5/6	OFF	OFF	OFF	OFF	OFF	ON	OFF	ON
Bard ID= 0x07 COM= 7/8	OFF	OFF	OFF	OFF	OFF	ON	ON	ON
Bard ID= 0x09 COM= 9/10	OFF	OFF	OFF	OFF	ON	OFF	OFF	ON
Bard ID= 0x14 COM= 20/21	OFF	OFF	OFF	ON	OFF	ON	OFF	OFF
Bard ID= 0x1E COM= 30/31	OFF	OFF	OFF	ON	ON	ON	ON	OFF
Bard ID= 0x28 COM= 40/41	OFF	OFF	ON	OFF	ON	OFF	OFF	OFF
Bard ID= 0x32 COM= 50/51	OFF	OFF	ON	ON	OFF	OFF	ON	OFF
Bard ID= 0x3C COM= 60/61	OFF	OFF	ON	ON	ON	ON	OFF	OFF
Bard ID= 0x64 COM= 100/101	OFF	ON	ON	OFF	OFF	ON	OFF	OFF
.
.
.
Bard ID= 0xFF COM= 255/256	ON	ON	ON	ON	ON	ON	ON	ON

2.2.2 VXC/VEX-114/144 Series cards

The COM port mapping configuration examples are as follows:

If Setting SW1 dip-switch (COM Selector) to 0x05 (1 and 3 “NO→1”, others “OFF→0”). The setting forces the 4-port VXC/VEX series card to use **COM5, COM6, COM7 and COM8**.

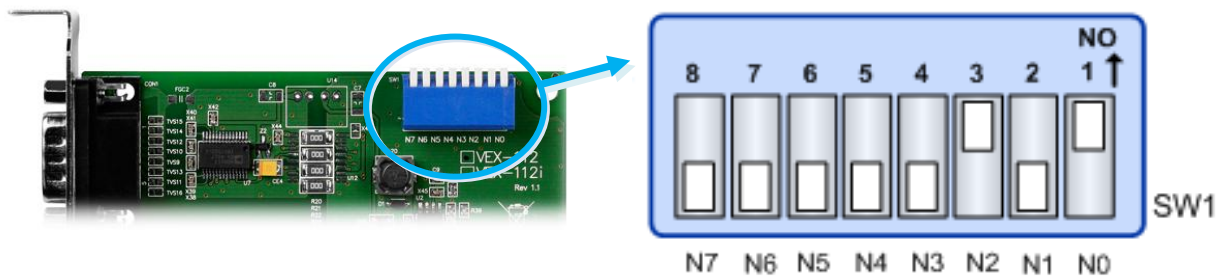

■ SW1 Setting Table for the VXC/VEX-114/144 Series (4-Port):

SW1 DIP Switch	8	7	6	5	4	3	2	1
Board ID= 0x00 (Default) COM = Auto-defined	OFF	OFF	OFF	OFF	OFF	OFF	OFF	OFF
Bard ID= 0x03 COM= 3/4/5/6	OFF	OFF	OFF	OFF	OFF	OFF	ON	ON
Bard ID= 0x05 COM= 5/6/7/8	OFF	OFF	OFF	OFF	OFF	ON	OFF	ON
Bard ID= 0x07 COM= 7/8/9/10	OFF	OFF	OFF	OFF	OFF	ON	ON	ON
Bard ID= 0x09 COM= 9/10/11/12	OFF	OFF	OFF	OFF	ON	OFF	OFF	ON
Bard ID= 0x14 COM= 20/21/22/23	OFF	OFF	OFF	ON	OFF	ON	OFF	OFF
Bard ID= 0x1E COM= 30/31/32/33	OFF	OFF	OFF	ON	ON	ON	ON	OFF
Bard ID= 0x28 COM= 40/41/42/43	OFF	OFF	ON	OFF	ON	OFF	OFF	OFF
Bard ID= 0x32 COM= 50/51/52/53	OFF	OFF	ON	ON	OFF	OFF	ON	OFF
Bard ID= 0x3C COM= 60/61/62/63	OFF	OFF	ON	ON	ON	ON	OFF	OFF
Bard ID= 0x64 COM= 100/101/102/103	OFF	ON	ON	OFF	OFF	ON	OFF	OFF
Bard ID= 0x96 COM= 150/151/152/153	ON	OFF	OFF	ON	OFF	ON	ON	OFF
Bard ID= 0xC8 COM= 200/201/202/203	ON	ON	OFF	OFF	ON	OFF	OFF	OFF
.
.
Bard ID= 0xFF COM= 255/256/x/x	ON	ON	ON	ON	ON	ON	ON	ON

2.3 Wiring Notes for RS-232/422/485

2.3.1 RS-232 Wiring

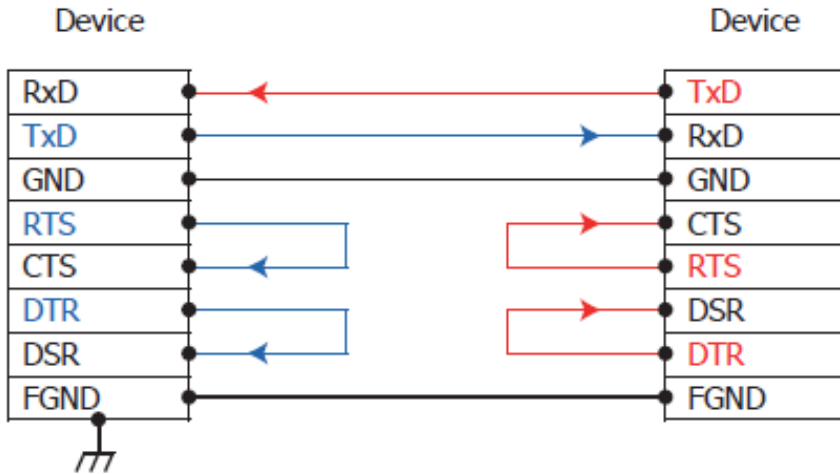

3-wire RS-232 Connection
(Shorts unused signals RTS/CTS, DTR/DSR)

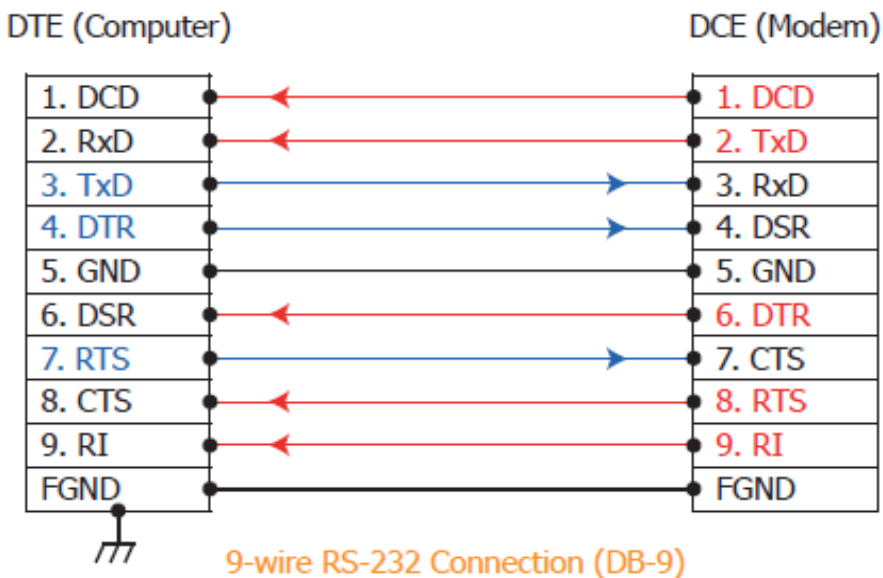

9-wire RS-232 Connection (DB-9)



Notes:

1. For 3-wire RS-232 connection, it's recommended to short unused signals such as RTS/CTS and DTR/DSR, since some systems may still check the CTS and DSR status.
2. FGND is the frame ground that is soldered to the metal shield on the DB-9 cable.

2.3.2 RS-422/485 Wiring

■ RS-485 wiring:

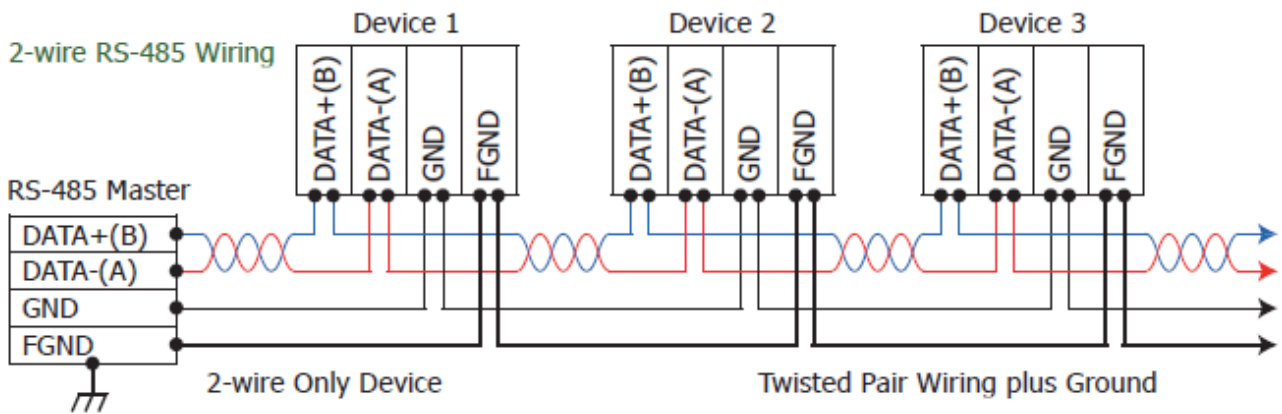

■ RS-422 wiring:

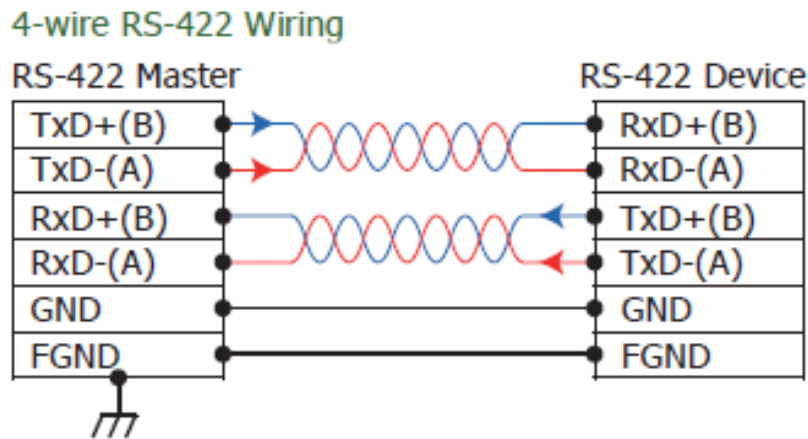

Notes:

1. For non-isolated RS-422/485 ports, all signal grounds for RS-422/485 devices should be connected together as this reduces the common-mode voltage between devices.
2. A twisted-pair cable must be used for the Data+/- wires.
3. Both ends of the cable may require a termination resistor to be connected across the two Data+ and Data- wires. Typically, a 120 Ω resistors is used.

2.4 Pin Assignments

2.4.1 VXC/VEX-112 Series

Pin Assignment	Terminal	No.	Pin Assignment
GND	05	09	RI
DTR	04	08	CTS
TxD	03	07	RTS
RxD	02	06	DSR
DCD	01		



Male DB-9 Connector

2.4.2 VXC/VEX-142 Series

Pin Assignment	Terminal	No.	Pin Assignment
GND/VEE	05	09	CTS-(A)
RxD-(A)	04	08	CTS+(B)
RxD+(B)	03	07	RTS+(B)
TxD+(B)/Data+(B)	02	06	RTS-(A)
TxD-(A)/Data-(A)	01		



RS-422/485 Male DB-9 Connector

2.4.3 VXC/VEX-114 Series

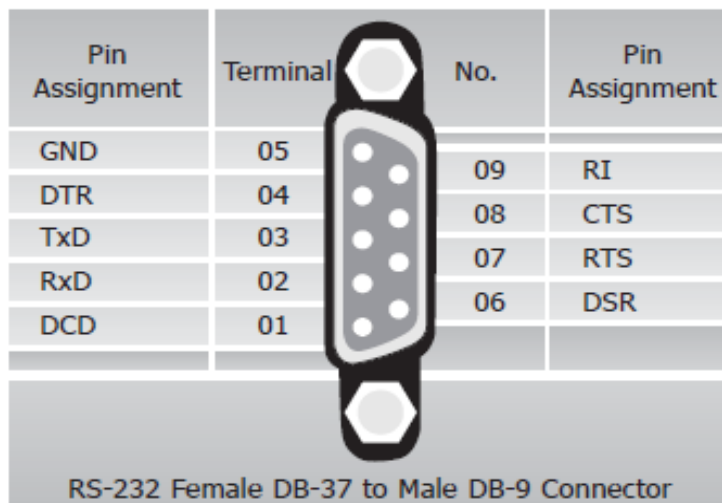
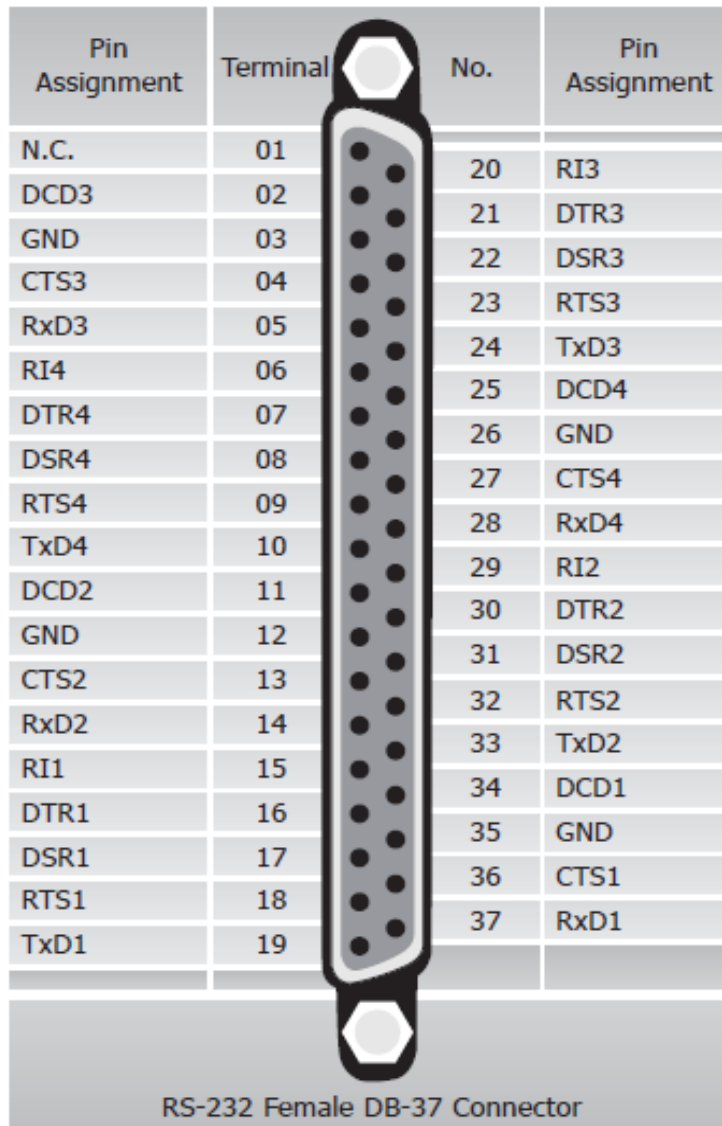

2.4.4 VXC/VEX-144 Series

Pin Assignment	Terminal	No.	Pin Assignment
N.C.	01	20	CTS3-(A)
TxD3-(A)/Data3-(A)	02	21	RxD3-(A)
GND	03	22	RTS3-(A)
CTS3+(B)	04	23	RTS3+(B)
TxD3+(B)/Data3+(B)	05	24	RxD3+(B)
CTS4-(A)	06	25	TxD4-(A)/Data4-(A)
RxD4-(A)	07	26	GND/VEE4
RTS4-(A)	08	27	CTS4+(B)
RTS4+(B)	09	28	TxD4+(B)/Data4+(B)
RxD4+(B)	10	29	CTS2-(A)
TxD2-(A)/Data2-(A)	11	30	RxD2-(A)
GND/VEE2	12	31	RTS2-(A)
CTS2+(B)	13	32	RTS2+(B)
TxD2+(B)/Data2+(B)	14	33	RxD2+(B)
CTS1-(A)	15	34	TxD1-(A)/Data1-(A)
RxD1-(A)	16	35	GND/VEE1
RTS1-(A)	17	36	CTS1+(B)
RTS1+(B)	18	37	TxD1+(B)/Data1+(B)
RxD1+(B)	19		



RS-422/485 Female DB-37 Connector

Pin Assignment	Terminal	No.	Pin Assignment
GND/VEE	05	09	CTS-(A)
RxD-(A)	04	08	CTS+(B)
RxD+(B)	03	07	RTS+(B)
TxD+(B)/Data+(B)	02	06	RTS-(A)
TxD-(A)/Data-(A)	01		

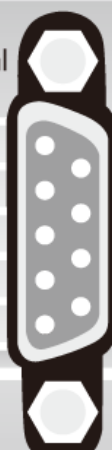

RS-422/485 Female DB-37 to Male DB-9 Connector

2.4.5 VXC-182 Series

■ CON1: Isolation RS-422/485 Port:

Pin Assignment	Terminal	No.	Pin Assignment
GND/VEE	05	09	CTS-(A)
RxD-(A)	04	08	CTS+(B)
RxD+(B)	03	07	RTS+(B)
TxD+(B)/Data+(B)	02	06	RTS-(A)
TxD-(A)/Data-(A)	01		



RS-422/485 Male DB-9 Connector

■ CON2: RS-232 Port:

Pin Assignment	Terminal	No.	Pin Assignment
GND	05	09	RI
DTR	04	08	CTS
TxD	03	07	RTS
RxD	02	06	DSR
DCD	01		



COM2: RS-232 Male DB-9 Connector

3. Hardware Installation



Notes:

1. *As certain operating systems, such as Windows 2000/XP may require the computer to be restarted after a new driver is installed, it is recommended that the driver is installed first, which will reduce the installation time.*
2. *Static electricity can easily damage computer equipment. It is recommended that your ground yourself by touching the chassis of the computer before handling any of the boards.*

Follow the process described below to install your VXC/VEX series card:

Step 1: Install the VXC/VEX series card driver on your computer.



For detailed information regarding driver installation, refer to [Chapter 4 Software Installation](#).

Step 2: Configuring COM port mapping (board ID) by the SW1 DIP-Switch.

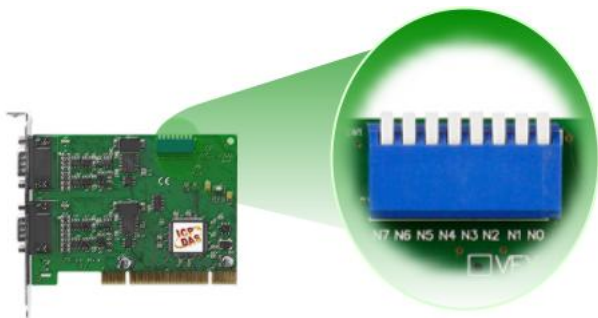

For detailed information regarding the COM port mapping (board ID), refer to [Sec. 2.2 SW1 DIP Switch \(COM Port Mapping\)](#).



Step 3: Correctly shut down and power off your computer, and then disconnect the power supply

Step 4: Remove the cover from the computer.

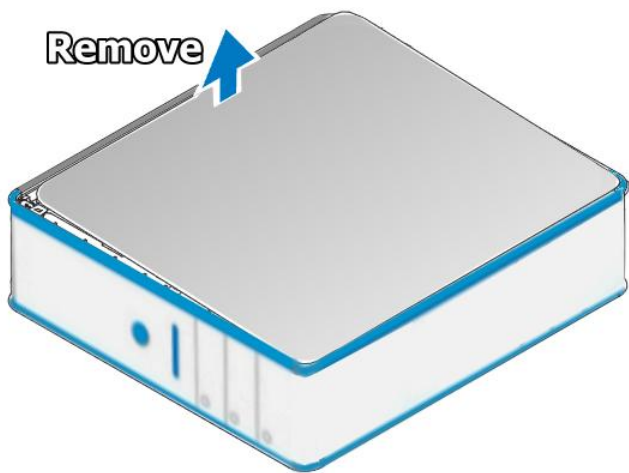

Step 5: Select an empty PCI/PCI Express slot.

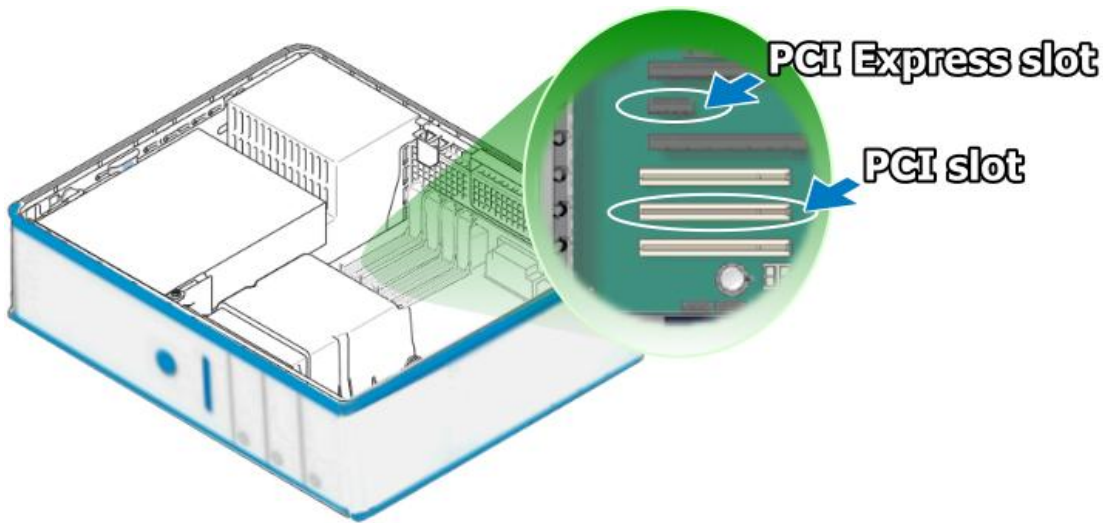

Step 6: Remove the screw holding the cover for the PCI/PCI Express slot in place and then remove the slot cover from the PC. Ensure that you do not misplace the screw.

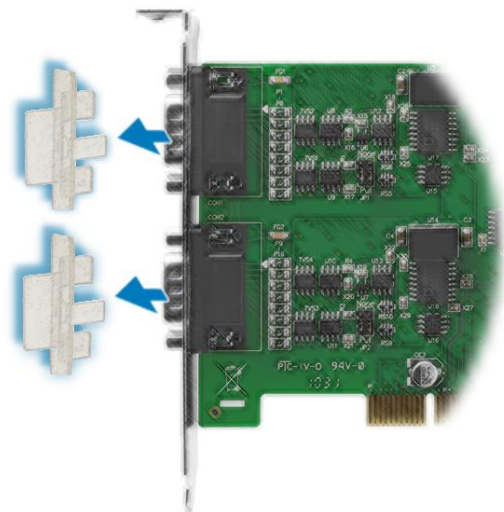
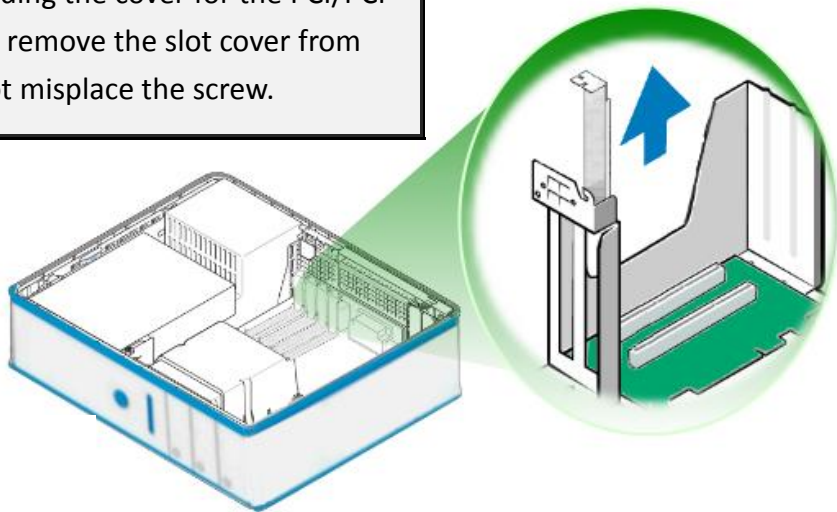

Step 7: Remove the connector cover from the VXC/VEX series card.

Step 8: Align the contacts of the PCI/PCI Express card with the open slot on your motherboard and carefully insert your VXC/VEX series card into the PCI/PCI Express slot.

VXC Series Card

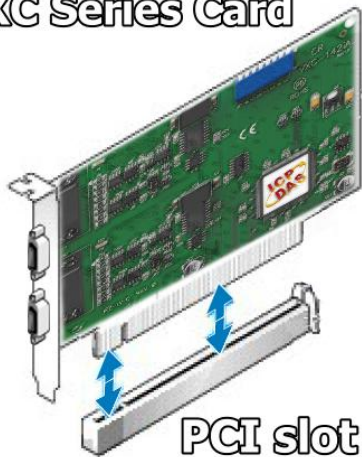

PCI slot

VEX Series Card

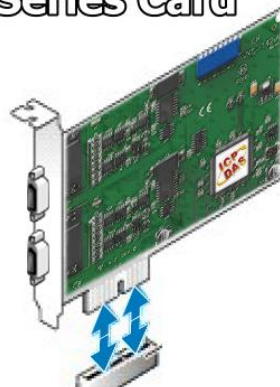

PCI Express slot

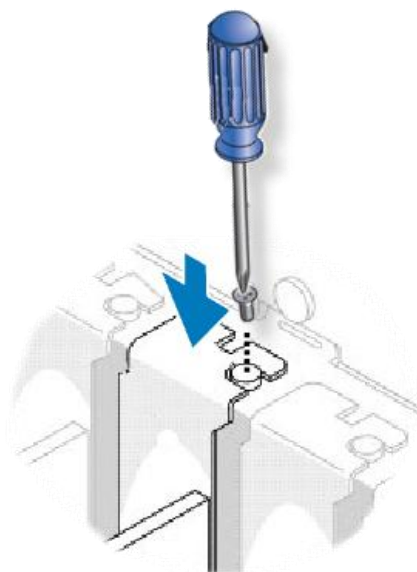

Step 9: Screw the mounting bracket screw removed in step 5 into the new PCI/PCI Express card bracket to secure the card in place.

Confirm that the VXC/VEX series card is correctly mounted on the motherboard.

Step 10: Re-attach cover for the computer and reconnect the power supply.

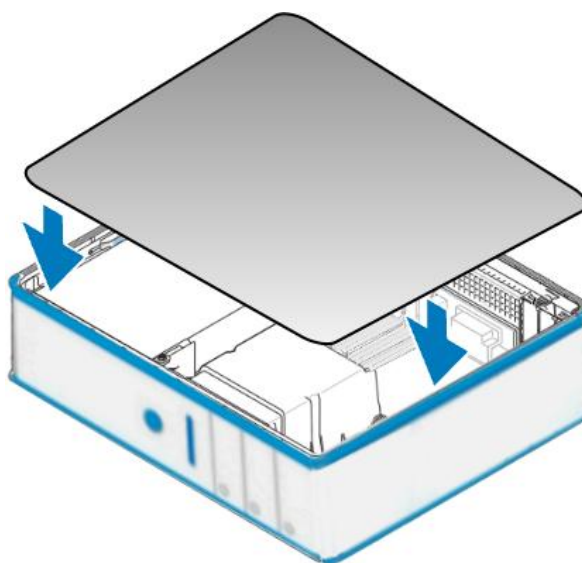

Step 11: Power on the computer.



Once the computer reboots, follow the onscreen messages to complete the Plug & Play installation process. For more information, refer to [Chapter 4 Software Installation](#).

4. Software Installation

The VXC/VEX series card can be used with both DOS, Linux and Windows 2000 and 32/64-bit Windows XP/2003/2008/Vista32/Windows 7 systems, and also supports Plug & Play functions for easy installation. This chapter provides a detailed description of how to install the drivers for the VXC/VEX series card.

4.1 Obtaining the Driver Installer Package

The installer package for the ICP DAS VXC/VEX series driver can be obtained from either the companion CD-ROM, the FTP site, or the ICP DAS web site. The locations and addresses are show below:



CD:\\ NAPDOS\MultiPort\Windows



<ftp://ftp.icpdas.com/pub/cd/iocard/pci/napdos/multiport/>



<http://ftp.icpdas.com/pub/cd/iocard/pci/napdos/multiport/>

Install the appropriate driver for your operating system, as follows:

Folder	Setup File	OS
Windows	VxCardWin32_64_x_x_x_x.exe	for Windows 2000/XP/2003/2008/Vista and Windows 7(32/64-bit) For detailed information about the Windows driver installation, please refer to section 4.2 .
Linux	ixcom.tar.gz	for Linux 2.4.X/2.6.X/3.12.X For detailed information about the Linux driver installation, please refer to section 4.7 .
DOS	DOS Library files	for DOS

4.2 Installing VxCard Driver under Windows

Follow the process described below to set up the software for the VXC/VEX series card:

Step 1: Double Click the
“VxCardWin32_64_x_xx_xx.exe” to install the driver.

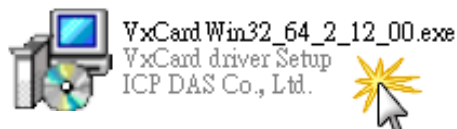

Step 2: When the setup Wizard screen is displayed, click the “**N**ext>” button to begin the installation.

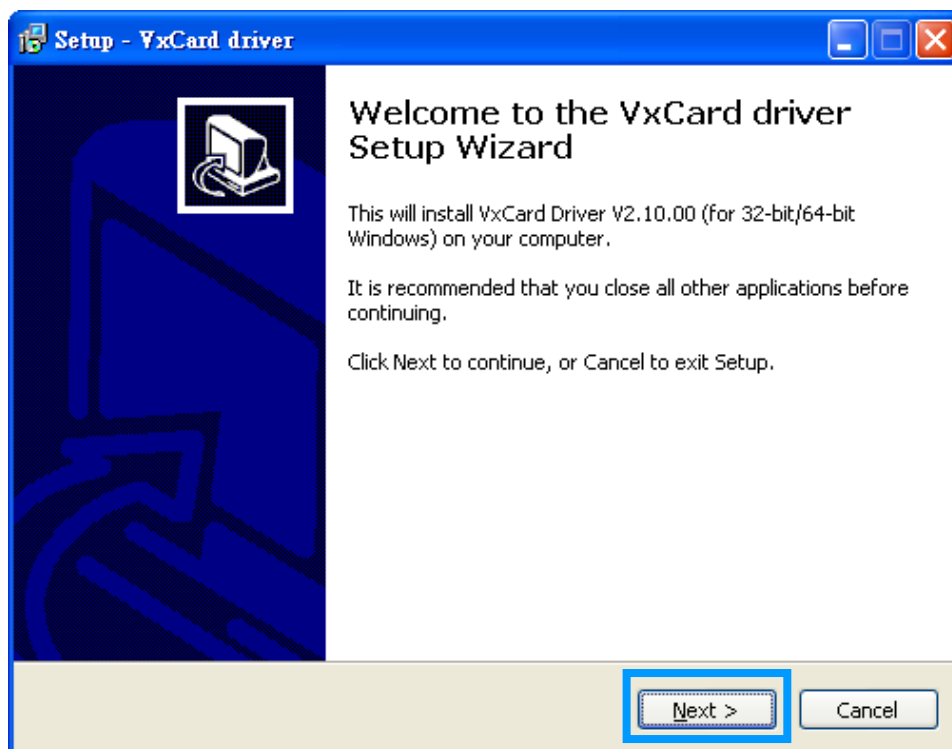

Step 3: Select the folder where the drivers are to be install.

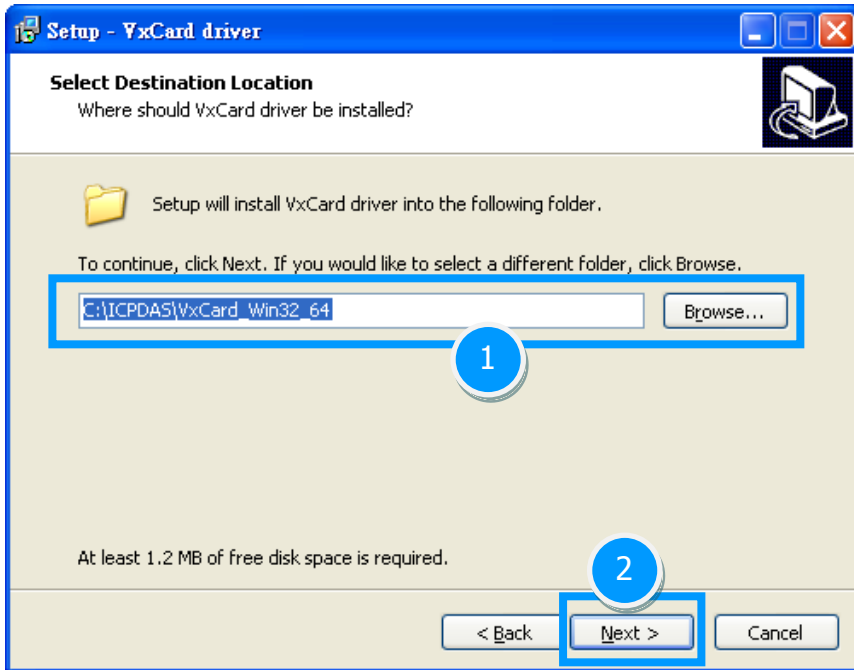

The default path is C:\ICPDAS\VxCard_Win32_64, but if you wish to install the drivers to a different location, click the “Browse...” button and select the relevant folder and then click then “Next>” button.



Note: More recent operating system, such as Windows Vista/7, will display a warning message asking you to confirm that your wish to install the device software, refer to figure below.

Step 1: In the “Windows Security” dialog box, check the “Always trust software from “ICP DAS Co., LTD.”” Checkbox.

Step 2: Click the “Install” button.

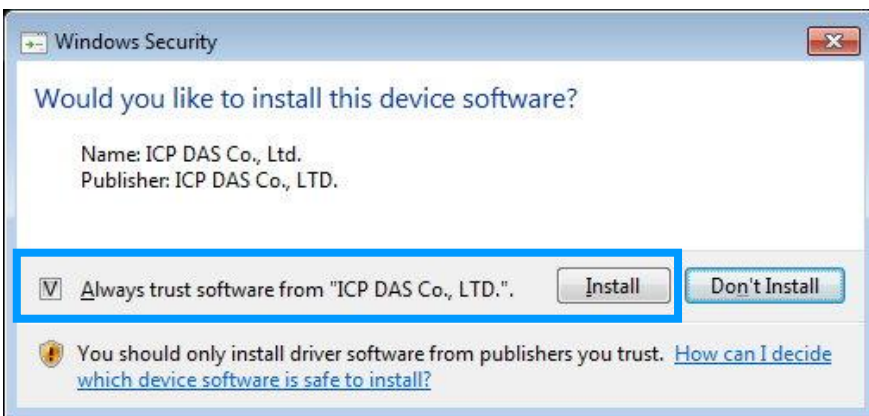

This warning will be displayed several times. In all cases, click the “Install” button to proceed with the installation.

Step 4: Once the driver has been installed, the Setup Wizard will be displayed to advise that the computer must be restarted in order to complete the installation.

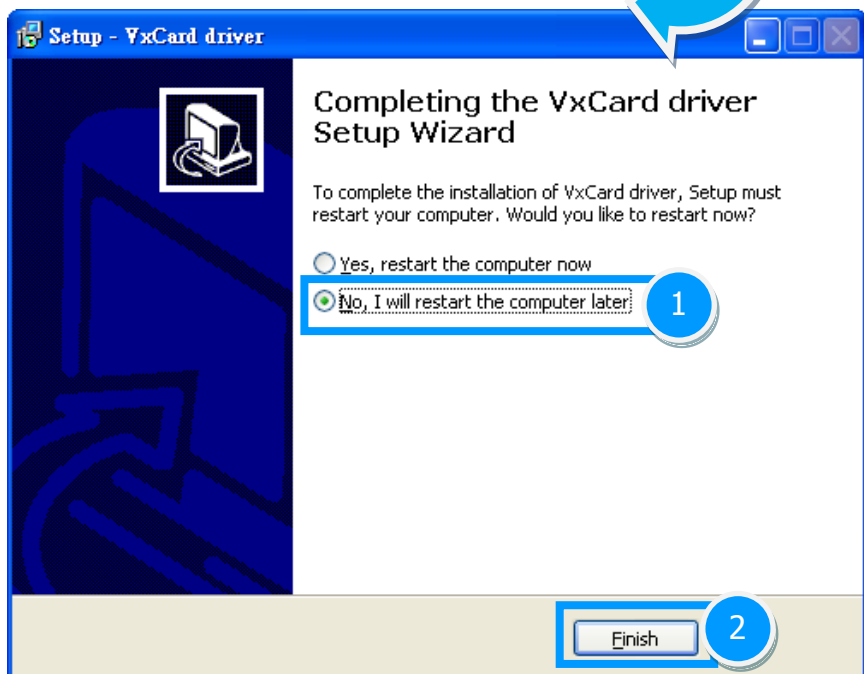
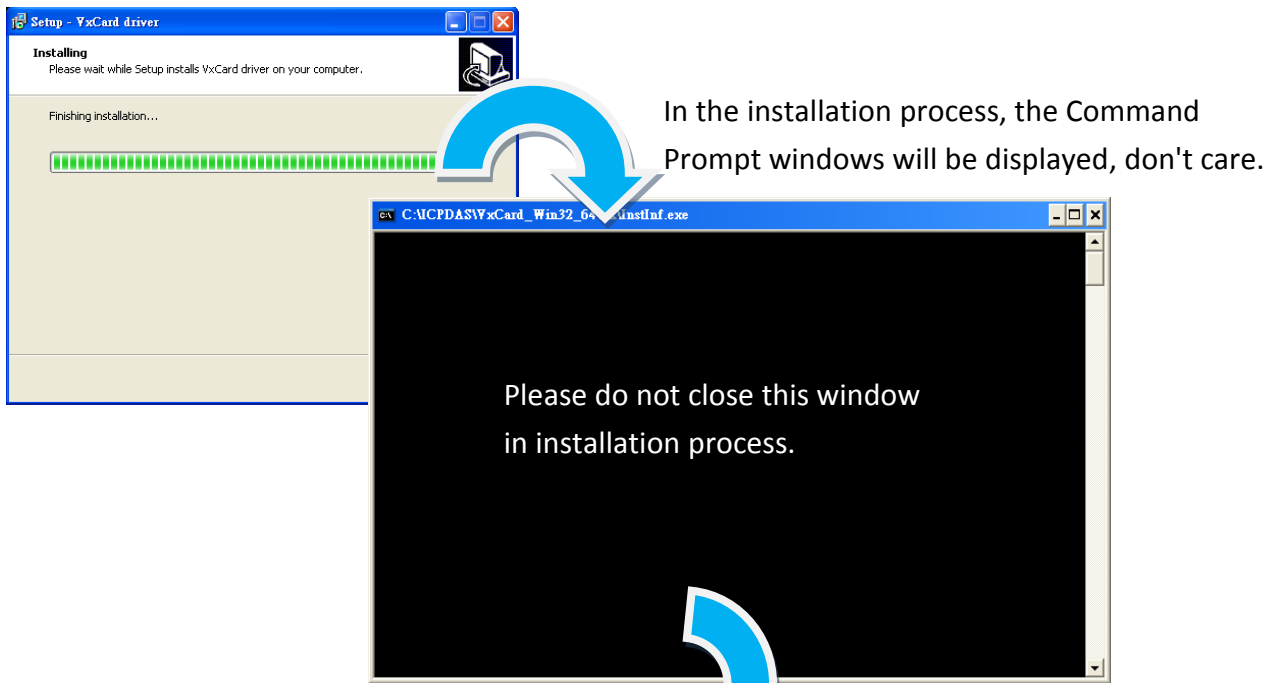

Select the “**No, I will restart the computer later**” option, and then click the “**Finish**” button to exit the Wizard.

4.3 PnP Driver Installation

Step 1: Correctly shut down and power off your computer and disconnect the power supply, and then install the VXC/VEX series card into the computer.

For detailed information regarding installation of the VXC/VEX series card, refer to [Chapter 3 Hardware Installation](#).

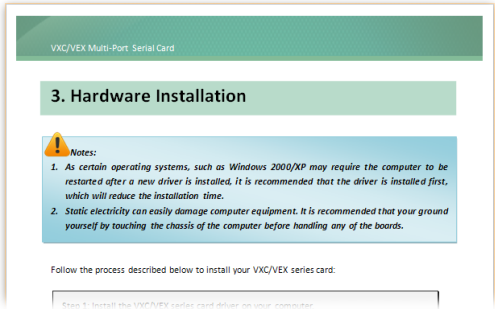

Step 2: Power on the computer and complete the Plug & Play installation.

 **Note:** More recent operating system, such as Windows Vista/7, will automatically detect the new hardware and install the necessary drivers etc., so Steps 3 to 5 can be skipped.

Step 3: When the “Found New Hardware Wizard” is displayed, select “Install the software automatically [Recommended]” option and then click the “Next>” button.

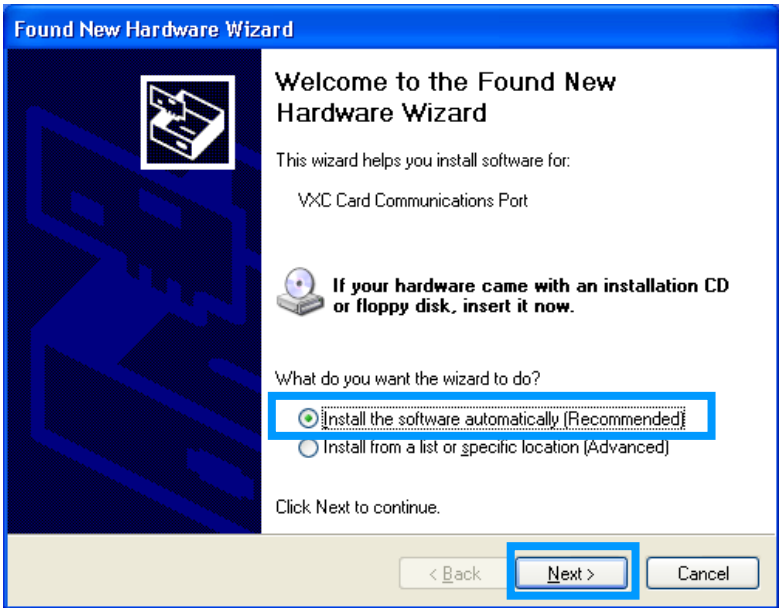

Step 4: The **“Found New Hardware Wizard”** will be displayed to advise that the software installation has been completed. Click the **“Finish”** button to exit the Wizard.

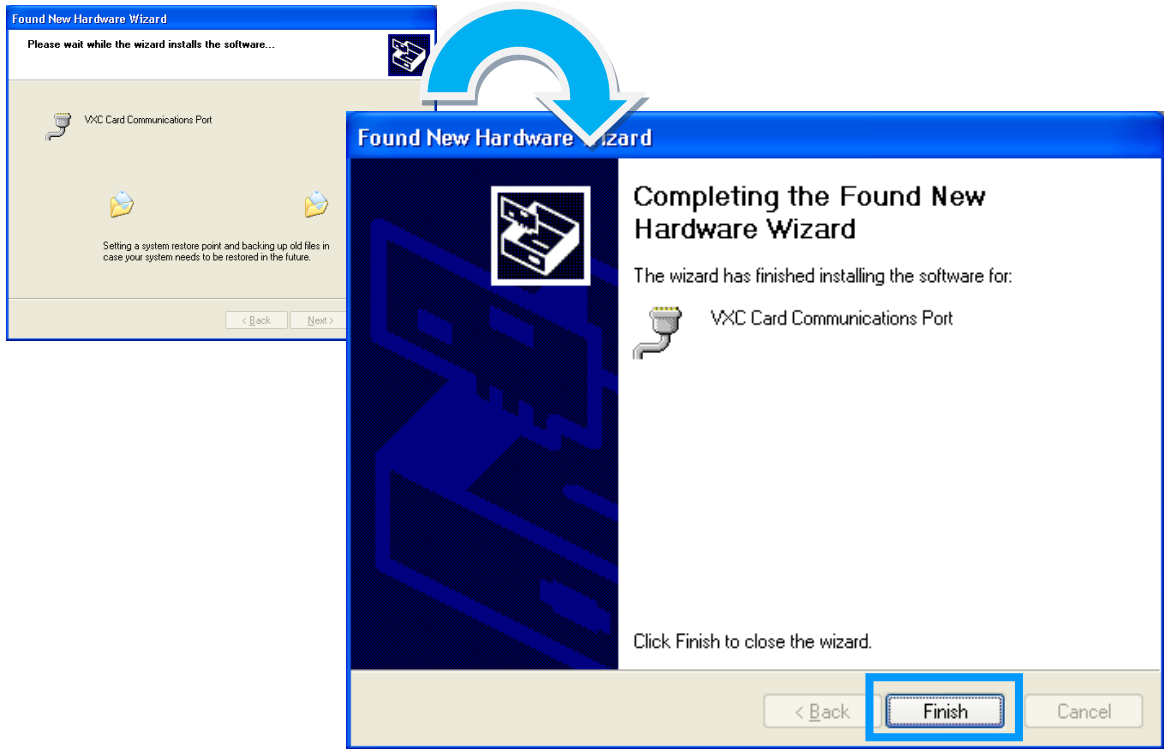

Step 5: If the **“Found New Hardware Wizard”** dialog box is displayed again, repeat **Steps 3 and 4** to complete the installation for all COM ports.



4.4 Verifying the Installation

To verify the installation, use the Windows **Device Manager** to view and update the device drivers installed on your computer, and check to ensure that hardware is operating correctly. The following is a description of how access the Device Manager in each of the major versions of Windows. Refer to the appropriate description for your specific operating system to verify the installation.

4.4.1 How do I access Windows Device Manager?

■ Microsoft Windows 2000/XP

Step 1: Click **“Start”** → then point to **“Settings”** and click → **“Control Panel”**. Double-click the **“System”** icon to open the **“System Properties”** dialog box.

Step 2: Click the **“Hardware”** tab, and then click the **“Device Manager”** button.

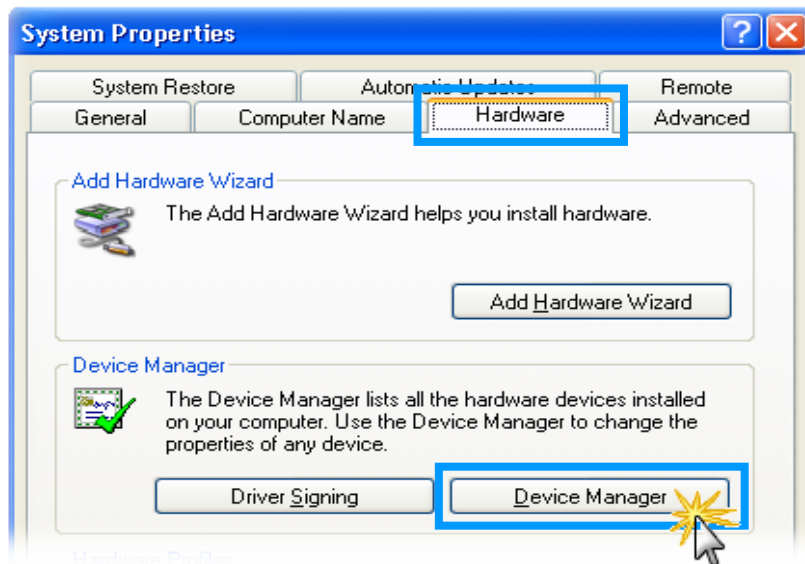

■ Microsoft Windows Server 2003/2008

Step 1: Click “Start” → point to “Administrative Tools”, and then click “Computer Management”.

Step 2: From “System Tools” in the console tree, click “Device Manager”.

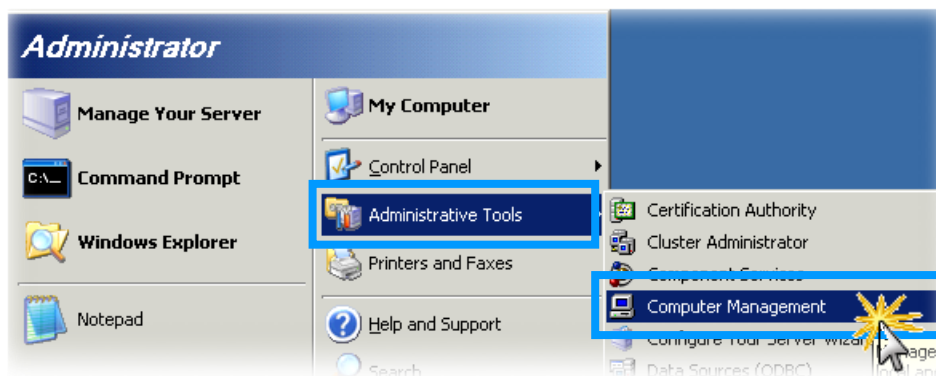

■ Microsoft Windows Vista/7

Step 1: Click “Start” button, and then click “Control Panel”.

Step 2: Click “System and Maintenance”, and then click “Device Manager”.

Alternatively,

Step 1: Click “Start” button.

Step 2: In the Search field, type Device Manager and the press Enter.

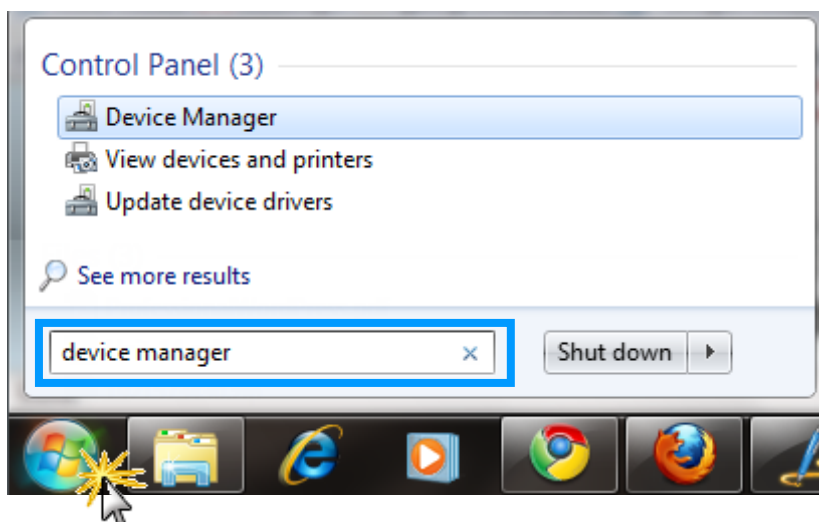

Note that Administrator privileges are required for this operation. If you are prompted for an administrator password or confirmation, type the password or provide confirmation.

4.4.2 Check the Configuration of the COM Port

Step 3: Verify that the COM ports for the VXC/VEX series card are listed correctly.

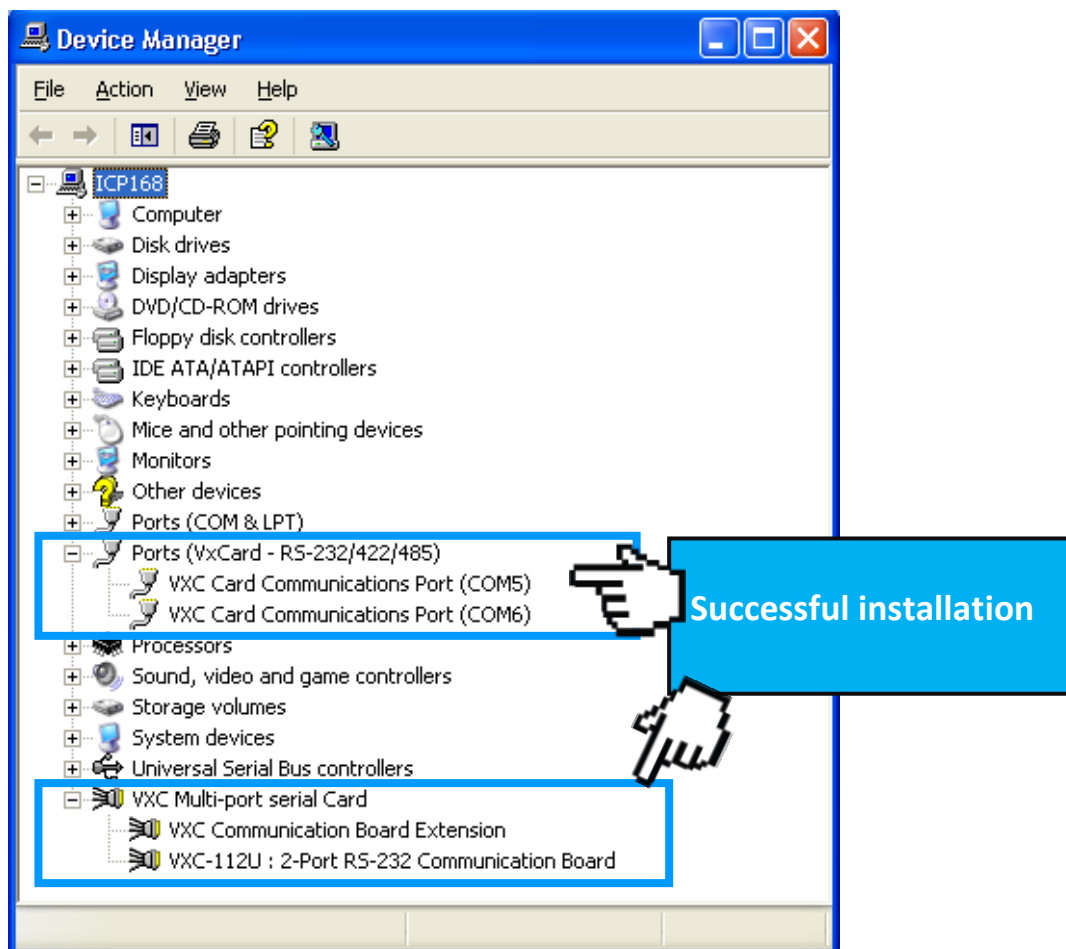

4.5 Configuration COM Port Buffer Size

The VXC/VEX series driver includes a **VxCard Utility** that allows the users can change the input buffer size (default is 4 KB for each port, up to 128 KB) by setting the “SW FIFO” scroll-bar on the **VxCard Utility**. The VxCard Utility can be found in the the driver installation folder, for example **C:\ICPADS\VxCard_Win32_64**.

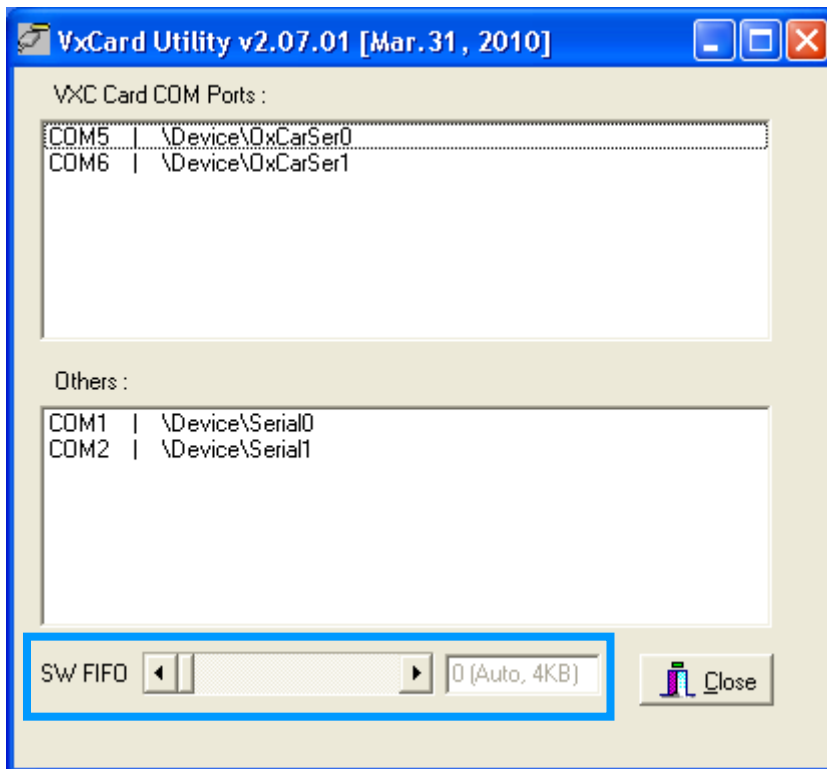

Note:

If necessary, the COM port mapping can be adjusted, refer to the following:

Step 1: Change the COM port mappings (see [Section 2.2 SW1 DIP Switch \(COM Port Mapping\)](#)).

Step 2: Restart the driver by rebooting the computer.

or

Step 2: Re-install the “**VXC/VEX Card**” hardware in the “**Device Manager**” by un-install card and then scan new hardware.

4.6 Uninstalling the Device Driver

The VXC/VEX series driver includes a uninstall driver utility that allows the software to be removed from your computer. To uninstall the software, follow the process described below:

Step 1: Open the driver installation folder, for example **C:\ICPADS\VxCard_Win32_64**, and then double-click the **unins000.exe** uninstaller application.



Step 2: The uninstaller application will then ask you to confirm that you wish to remove the utility program. Click the **“Yes”** button to continue.

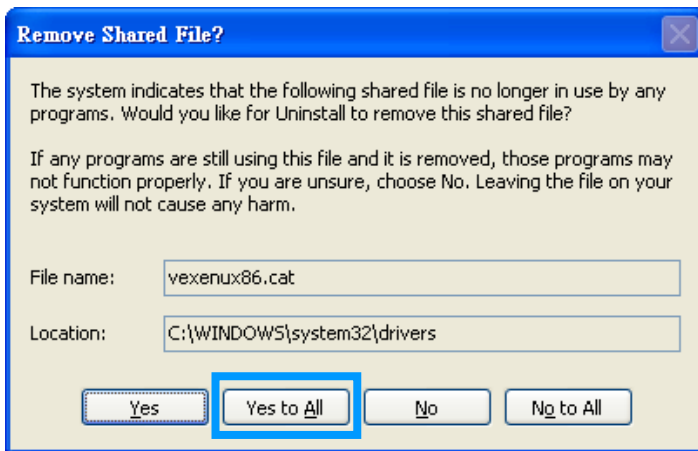
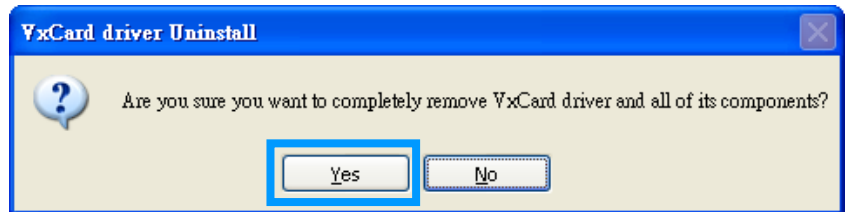

Step 3: The **“Remove Shared File?”** dialog box will be displayed asking whether you wish to remove the shared file. Click the **“Yes to All”** button to continue.

Step 4: After the uninstallation process is complete, a dialog box will be displayed to notify that the driver was successfully removed. Click the **“OK”** button to finish.

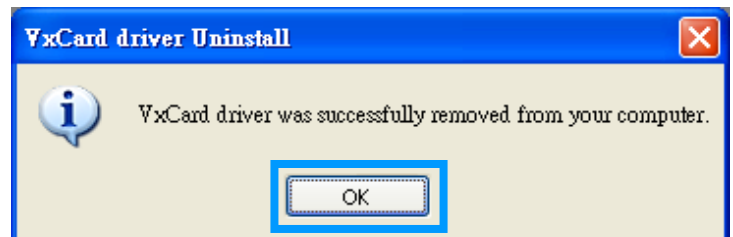

4.7 Installing VxCard Driver under Linux

This section describes VXC/VEX series card Linux driver's features and how to compile and install into a general Linux system (Linux kernel 2.4.X, 2.6.X or 3.12.X). The VXC/VEX series card Linux driver is modified from Linux kernel source and supports most of popular PC-based Linux distributions.

4.7.1 Driver Features

- Device file.
- Dynamic device allocation.
- Dynamic major number.
- One major number for multiple devices.
- Use the GNU configure and build system.

4.7.2 Installation

To install Linux driver, complete the following steps:

Step 1: Download or copy the **IxCOM** package to a directory that you have access to.



Please refer to [section 4.1 "Obtaining the Driver Installer Package"](#) getting the location of **IxCOM** package.

Step 2: Extract the **IxCOM** package. For example, the package's file name is "**ixcom-0.8.1.tar.gz**" and its path related to your current working directory is `.../pkg`, then the extraction command would be

```
#tar -zxvf ../pkg/ixcom-0.8.1.tar.gz
```

An `ixcom-0.8.1` directory is created after extraction.

Step 3: For convenient access, it is a good idea to put a symbol-link on it.

```
#ln -s ixcom-0.8.1 ixcom
```

Step 4: Change to the **ixcom** working directory you just made, type

```
#!/configure to create proper Makefiles.
```

Step 5: Once the configuring has done successfully, type **“make”** to build all.



Note:

If you like to install files to system directory, the make install will do it for you. However, install files to system directory is not necessary for further operation. You will need the root privilege for that.

Script **“./ixcom.inst”** loads modules automatically. Script **“./ixcom.remove”** removes the loaded modules. The root privilege is required when installing or removing these kernel modules.

4.7.3 Access to VXC/VEX Serial Port

Script **“ixcom.inst”** will establish unused device major number dynamically and create correspond device node for access VXC/VEX serial port.

```
# ./ixcom.inst
IxCOM Installer 0.5.0
Check kernel version... 2.6
Use proc-file /proc/icpdas/ixcom
Load module ixcom
```

Use “**dmesg**” command to inspect the driver output message.

```
dmesg
.....
.....
ICPDAS VXC multi-serial card Serial driver version ixcom-0.8.1 (2007-08-21)
Found ICPDAS VXC-114U series board(BusNo=0,DevNo=20)
PCI: Found IRQ 11 for device 0000:00:14.0
PCI: Sharing IRQ 11 with 0000:00:07.2
PCI: Sharing IRQ 11 with 0000:00:14.1
ttySV0 at port cc00 (irq = 11) is a 16C950/954
ttySV1 at port d000 (irq = 11) is a 16C950/954
ttySV2 at port d400 (irq = 11) is a 16C950/954
ttySV3 at port d800 (irq = 11) is a 16C950/954
```

The script “**ixcom.inst**” had loaded module into kernel and find a VXC/VEX card that have four serial port, ttySV0, ttySV1, ttySV2 and ttySV3.

The “**ixcom.inst**” script will use major number 254 to create correspond device on the /dev.

```
# ls -la /dev/ttySV?
crw-rw-rw- 1 root root 254, 64 Jul 14 10:13 /dev/ttySV0
crw-rw-rw- 1 root root 254, 65 Jul 14 10:13 /dev/ttySV1
crw-rw-rw- 1 root root 254, 66 Jul 14 10:13 /dev/ttySV2
crw-rw-rw- 1 root root 254, 67 Jul 14 10:13 /dev/ttySV3
crw-rw-rw- 1 root root 254, 68 Jul 14 10:13 /dev/ttySV4
crw-rw-rw- 1 root root 254, 69 Jul 14 10:13 /dev/ttySV5
crw-rw-rw- 1 root root 254, 70 Jul 14 10:13 /dev/ttySV6
crw-rw-rw- 1 root root 254, 71 Jul 14 10:13 /dev/ttySV7
crw-rw-rw- 1 root root 254, 72 Jul 14 10:13 /dev/ttySV8
crw-rw-rw- 1 root root 254, 73 Jul 14 10:13 /dev/ttySV9
```

To remove VXC/VEX driver from system use script “**./ixcom.remove**” to removes the loaded modules.

5. Testing the VXC/VEX Series Card

This chapter provides detailed information about regarding the “self-test” process which enables the user to confirm whether or not the VXC/VEX series card is operating correctly. Before performing the “self-test” the hardware and driver installation must be completed. For detailed information regarding hardware and driver installation, refer to [Chapter 3 Hardware Installation](#) and [Chapter 4 Software Installation](#).

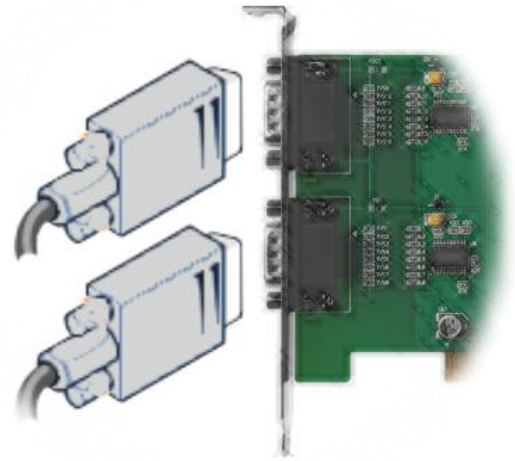

5.1 VXC/VEX-112/142 Series Card Wiring

Preparing the Device

Before beginning the “Self-test”, ensure that following items are available:

- A DN-09-2 (optional) terminal board
- Two CA-0910F (optional) cables

Step 1: Connect the DN-09-2 terminal board to the VXC/VEX-112 or VXC/VEX-142 series card using CA-0910F cable.

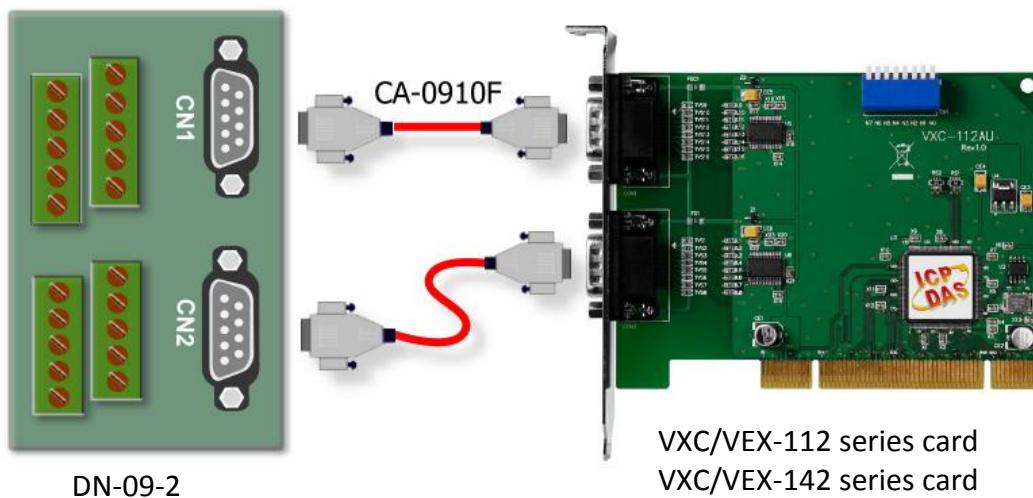

VXC/VEX-112 Series Card (RS-232):

CON2				CON1	
Pin Assignment	Pin No.		Pin No.		Pin Assignment
TxD	3	↔	2		RxD
RxD	2	↔	3		TxD

Step 2: Perform the “self-test” by shorting the RxD and TxD pins of both CON1 and CON2 connectors.

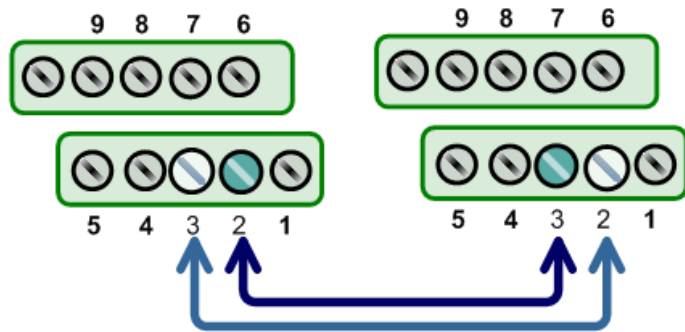

VXC/VEX-142 Series Card (RS-485):

CON2				CON1	
Pin Assignment	Pin No.		Pin No.		Pin Assignment
Data-	1	↔	1		Data-
Data+	2	↔	2		Data+

Step 2: Perform the “self-test” by shorting the CON2 Data+ and CON1 Data+ and CON2 Data- and CON1 Data- pins.

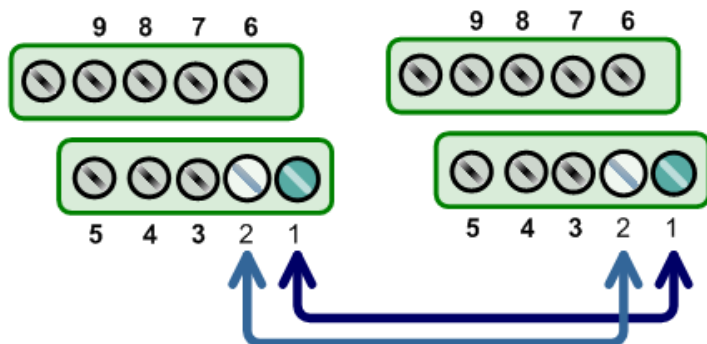

Note:

For detailed information regarding wiring and pin assignments for the RS-232/422/485, refer to [Section 2.3 Wiring Notes for RS-232/422/485](#) and [Section 2.4 Pin Assignments](#).

5.2 VXC-182 Series Card Wiring

Preparing the Device

Before beginning the “Self-test”, ensure that following items are available:

- A DN-09-2 (optional) terminal board
- A i-7250 (optional) Isolated RS-232 to Rs-485 converter module
- A CA-0910F (optional) cable
- A CA-0915 (optional) cable

Step 1: Connect the DN-09-2 terminal board to the CON1 on the VXC-182 series card using CA-0910F cable.

Step 2: Connect the I-7250 module to the CON2 on the VXC-182 series card using CA-0915 cable, ensure that converts RS-232 signals into RS-422/485 signal.

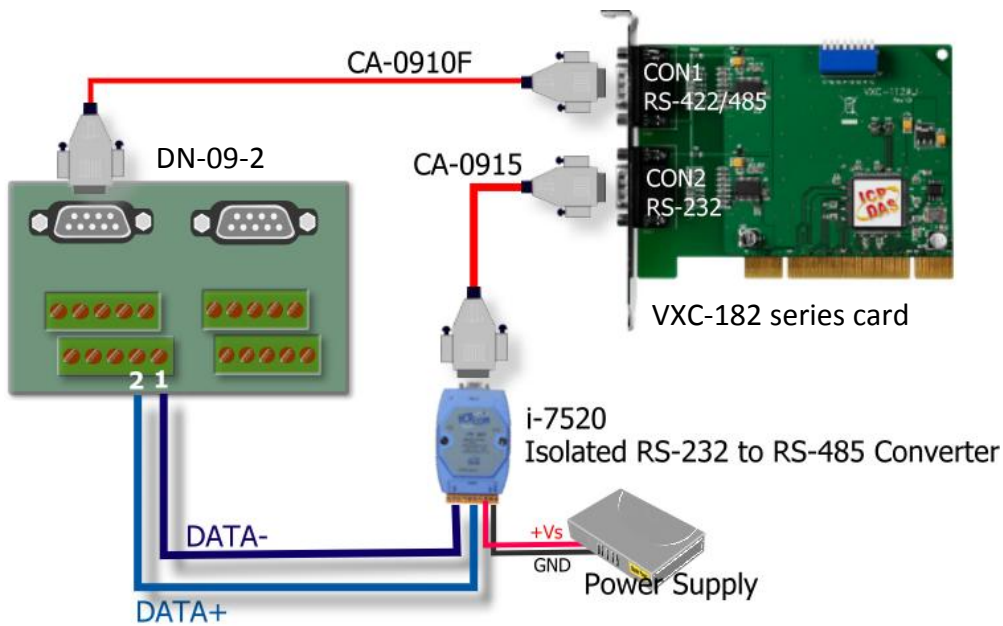

Step 3: Perform the “self-test” by shorting the **CON1 Data+ and CON2 Data+ and CON1 Data- and CON2 Data-** pins.

CON1 Pin Assignment	Pin No.		Pin No.	CON2 Pin Assignment
Data-	1	↔	1	Data-
Data+	2	↔	2	Data+



Note: For detailed information regarding wiring and pin assignments for the RS-232/422/485, refer to [Section 2.3 Wiring Notes for RS-232/422/485](#) and [Section 2.4 Pin Assignments](#).

5.3 VXC/VEX-114/144 Series Card Wiring

Preparing the Device

Before beginning the “Self-test”, ensure that following items are available:

- A DN-37 (optional) terminal board
- A CA-3710 (optional) cable

Step 1: Connect the DN-37 terminal board to the VXC/VEX-114 or VXC/VEX-144 series card using CA-3710 cable.

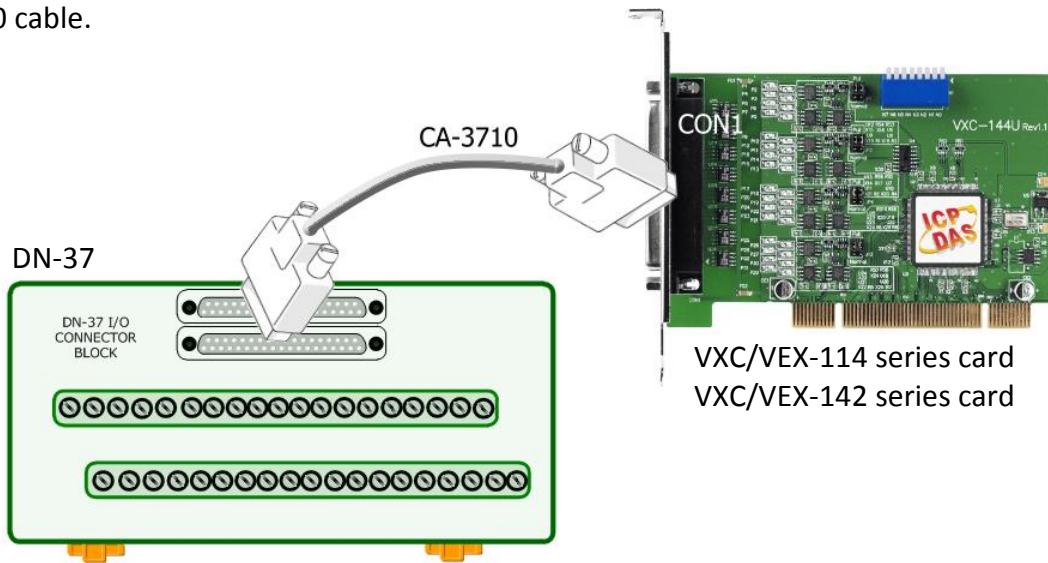

■ VXC/VEX-114 Series Card (RS-232):

Port-1 Pin Assignment	Pin No.		Pin No.	Port-2 Pin Assignment
TxD1	19	↔	14	RxD2
RxD1	37	↔	33	TxD2

Step 2: Perform the “self-test” by shorting the **RxD** and **TxD** pins of both **Port-1** and **Port-2**.

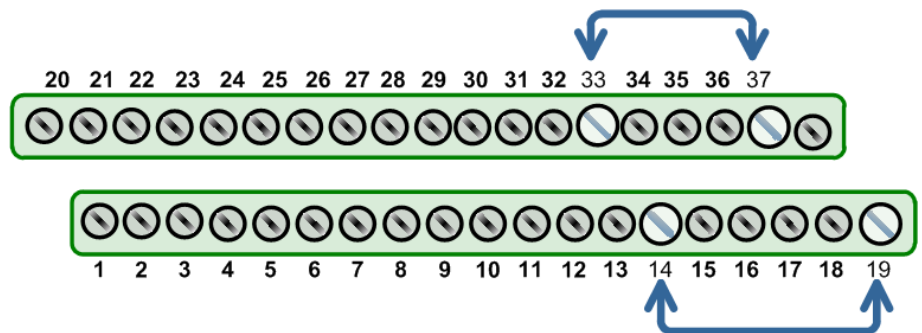

VXC/VEX-144 Series Card (RS-485):

Port-1 Pin Assignment	Pin No.		Pin No.	Port-2 Pin Assignment
Data1-	34	↔	11	Data2-
Data1+	37	↔	14	Data2+

Step 2: Perform the “self-test” by shorting the **Data1+** and **Data2+** and **Data1-** and **Data2-** pins of the **Port-1** and **Port-2**.

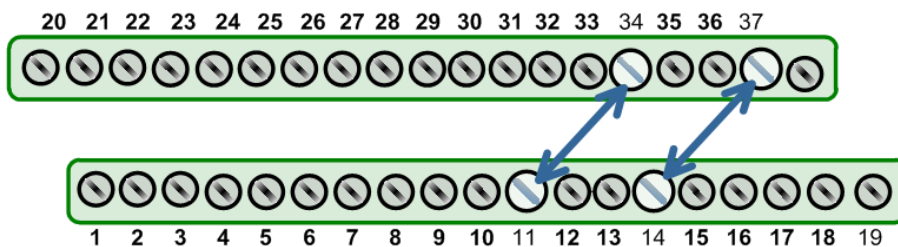

Note:

For detailed information regarding wiring and pin assignments for the RS-232/422/485, refer to [Section 2.3 Wiring Notes for RS-232/422/485](#) and [Section 2.4 Pin Assignments](#).

5.4 Self-Test

Step 1: Execute the **Test2COM.exe** application, which can be found on the companion CD at:
 CD:\Napdos\multiport\utility

Or download it from:

<http://ftp.icpdas.com/pub/cd/iocard/pci/napdos/multiport/utility/>



Step 2: Set the appropriate COM Ports, Baud Rate and Data Format information to the values shown in the image below.

- 1: COM Ports: Enter **COM5** (First), **COM6** (Second)
- 2: Data Bits: Check **5,6, 7 and 8**
- 3: Parity: Check **None, Odd and Even**
- 4: Stop Bits: Check **1 and 2**
- 5: Baud Rates: Check all for **9600 to 115200**
- 6: Loop: Type **1**
- 7: Click the **“Start Test”** button

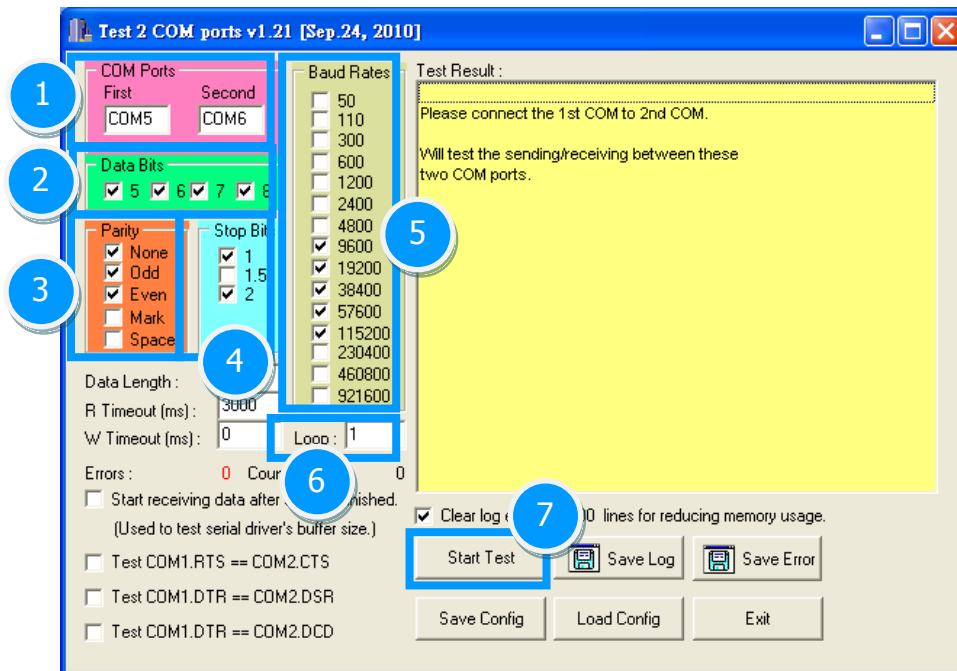

Notes:

1. You should first confirm the number of the COM Port for the VXC/VEX series card through the Device Manger (see [Section 4.4 Verifying the Installation](#)) and then this COM Port using the Test2COM application.
2. The Baud Rate and Data Format settings used in the Test2COM application depend on the COM Ports being used by the VXC/VEX series card. Refer to [Section 1.2 Specifications](#) for more detailed information.

Step 3: Refer to the test results. If the test was successful, the message “Failed Test: 0” will be displayed.

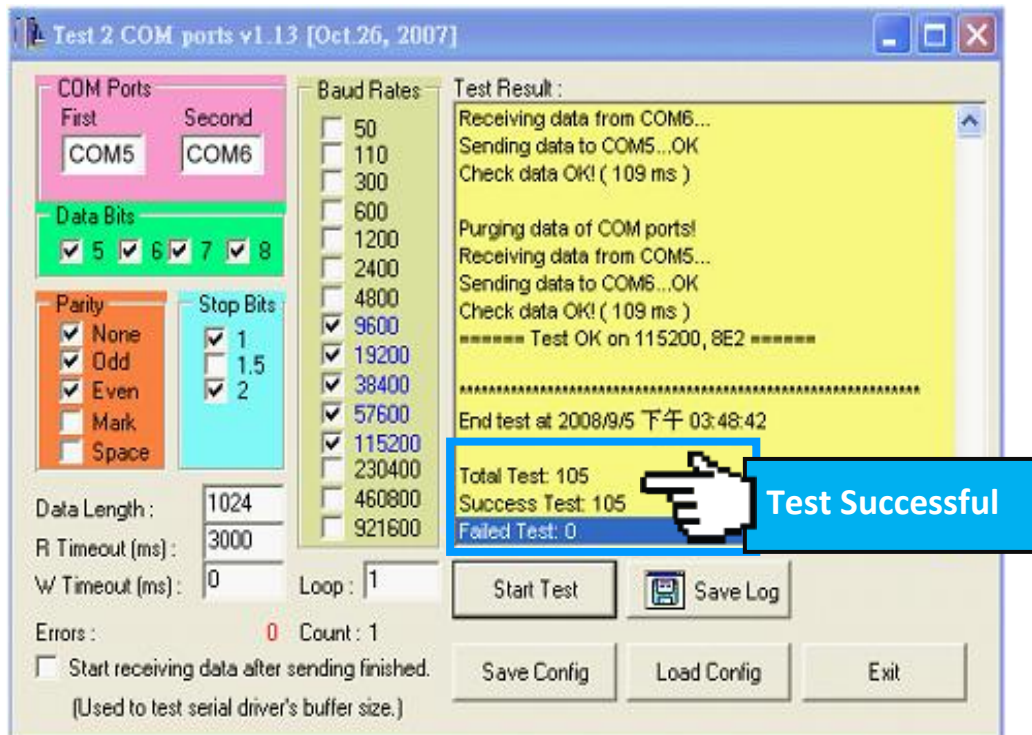

Step 4: The “self-test” process is now complete and your COM Port program can now be operated using this extended COM Port.



6. Programming Reference

6.1 PCI Hardware IDs

Model Name	Vendor ID	Device ID	Sub-Vendor ID	Sub-Device ID	Version
VXC-114U	0x1415	0x9504	0x1441	0x0090	Rev1.1
VXC-114iAU	0x1415	0x9501	0x1441	0x0091	Rev4.0
VXC-144U	0x1415	0x9504	0x1440	0x0090	Rev3.1
VXC-144iU	0x1415	0x9501	0x1440	0x0091	Rev4.0
VXC-112(A)U	0x1415	0x9501	0x1441	0x0080	Rev1.3
VXC-112iAU	0x1415	0x9505	0x1441	0x0080	Rev4.0
VXC-142(A)U	0x1415	0x9501	0x1440	0x0080	Rev1.2
VXC-142i(A)U	0x1415	0x9505	0x1440	0x0080	Rev4.0
VXC-182i(A)U	0x1415	0x9501	0x1442	0x0080	Rev1.1
	0x1415	0x9505	0x1442	0x0080	Rev4.0
VEX-114(i)	0x1415	0xC20D	0x1441	0x0091	Rev1.0
VEX-144(i)	0x1415	0xC20D	0x1440	0x0091	Rev1.0
VEX-112(i)	0x1415	0xC20D	0x1441	0x0080	Rev1.0
VEX-142(i)	0x1415	0xC20D	0x1440	0x0080	Rev1.0

6.2 I/O Address Mapping

The I/O address of the VXC/VEX series card is automatically assigned by the main-board ROM BIOS. The universal version of VXC/VEX series card using two PCI functions as followings:

Application: VXC-112U, VXC-142U/142iU, VXC-182iU, VXC-114U/114iAU (Version after Rev1.2), VXC-144U (Version after Rev1.2), VXC-144iU (Version after Rev3.2)		
Base Address Register	Function 0	Function 1
BAR0	UARTs (I/O Mapped)	Local Bus (I/O Mapped)
BAR1	UARTs (Memory Mapped)	Local Bus (Memory Mapped)
BAR2	Local Configuration Registers (I/O Mapped)	Reserved
BAR3	Local Configuration Registers (Memory Mapped)	Reserved
BAR4	Reserved	Reserved
BAR5	Reserved	Reserved

Application: VXC-112(A)U/112iAU (Rev4.0), VXC-142AU/142iAU (Rev4.0), VXC-182iAU (Rev4.0)		
Base Address Register	Function 0	Function 1
BAR0	UART0 (I/O Mapped)	Local Bus (I/O Mapped)
BAR1	UART1 (I/O Mapped)	Local Bus (Memory Mapped)
BAR2	Reserved	Reserved
BAR3	Reserved	Reserved
BAR4	Local Configuration Registers (I/O Mapped)	Reserved
BAR5	Local Configuration Registers (Memory Mapped)	Reserved



Note: Please contact us for more information about I/O Address Mapping.

Application: VXC-114U (Rev1.1), VXC-144U (Rev1.1), VXC-144iU (Rev3.1)		
Base Address Register	Function 0	Function 1
BAR0	UART0 (I/O Mapped)	Local Bus (I/O Mapped)
BAR1	UART1 (I/O Mapped)	Local Bus (Memory Mapped)
BAR2	UART2 (I/O Mapped)	Reserved
BAR3	UART3 (I/O Mapped)	Reserved
BAR4	Local Configuration Registers (I/O Mapped)	Reserved
BAR5	Local Configuration Registers (Memory Mapped)	Reserved

Application: VEX-114(i) (Rev1.0), VEX-144(i) (Rev1.0), VEX-112(i) (Rev1.0), VEX-142(i) (Rev1.0)		
Base Address Register	Function 0	Function 1
BAR0	GPIO (Memory Mapped)	UART (Memory Mapped)
BAR1	All visible Modules and MSI-X	All visible Modules and MSI-X (Used for MSI-X)
BAR2	Reserved	All visible Modules and MSI-X (Used for EEPROM)
BAR3	Reserved	Reserved
BAR4	Reserved	Reserved
BAR5	Reserved	Reserved



Note: Please contact us for more information about I/O Address Mapping.

6.3 UART Register

Register Name	Address	R/W	Bit 7	Bit 6	Bit 5	Bit 4	Bit 3	Bit 2	Bit 1	Bit 0
THR ¹	000	W	Data to be transmitted							
RHR ¹	000	R	Data received							
IER ^{1,2} 650/950 Mode 550/750 Mode	001	R/W	CTS interrupt	RTS interrupt	Special Char.	Sleep mode	Modem Interrupt mask	Rx Stat Interrupt mask	THRE Interrupt mask	RxRDY Interrupt mask
			Unused		Alternate Sleep mode					
FCR ³ 650 Mode 750 Mode 950 Mode	010	W	RHR Trigger Level		THR Trigger Level		Tx Trigger Enable	Flush THR	Flush RHR	Enable FIFO
			RHR Trigger Level		FIFO Size	Unused				
			Unused							
ISR ³	010	R	FIFOs Enabled		Interrupt priority (Enhanced mode)		Interrupt priority (All modes)			Interrupt Pending
LCR ⁴	011	R/W	Divisor Latch access	Tx break	Force Parity	Odd/Even parity	Parity enable	Number of stop bits	Data Length	
MCR ^{3,4} 550/750 Mode 650/920 Mode	100	R/W	Unused		CTS & RTS Flow Control	Enable Internal Loop Back	OUT2 (Int En)	OUT1	RTS	DTR
			Baud prescale	IrDA mode	XON-Arry					
LSR ^{3,5} Normal 9-bit data Mode	101	R	Data Error	Tx Empty	THR Empty	Rx Break	Framing Error	Parity Error	Overrun Error	RxRDY
							9 th Rx Data bit			
MSR ³	110	R	DCD	RI	DSR	CTS	Delta DCD	Trailing RI edge	Delta DSR	Delta CTS
SPR ³ Normal 6-bit data Mode	111	R/W	Temporary data storage register and indexed control register offset value bits							
			Unused							
Additional Standard Registers – These registers require divisor latch access bit (LCR[7]) to be set to 1.										
DLL	000	R/W	Divisor latch bits [7:0] (Least significant byte)							
DLM	001	R/W	Divisor latch bits [15:8] (Most significant byte)							

6.4 Programmable Baud Rate

■ Baud Rates Using a 14.7456 MHz Crystal (Universal PCI series card)

DESIRED BAUD RATE	DIVISOR USED TO GENERATE 16× CLOCK	PERCENT (%) ERROR
50	18432	
75	12288	
110	8376	0.026
150	6144	
300	3072	
600	1536	
1200	768	
2400	384	
4800	192	
9600	96	
14400	64	
19200	48	
23040	40	
28800	32	
38400	24	
56000	16	2.86
57600	16	
115200	8	
184320	5	
230400	4	
307200	3	
460800	2	



Warning: The baud rates higher than 115,200 bps are not guaranteed to work.

■ Baud Rates Using a 62.5 MHz Crystal (PCI Express series card)

DESIRED BAUD RATE	TCR Reg	CPR Bit(7:3)	DLM	DLL	PERCENT (%) ERROR
1200	0100	00100	0C	B6	0.037
2400	0100	00100	06	5B	0.037
4800	0100	00100	03	2D	0.099
9600	0100	00100	01	96	0.221
19200	0100	00100	00	CB	0.221
38400	0100	00100	00	66	-0.270
57600	0100	00100	00	44	-0.270
115200	0100	00100	00	22	-0.270
230400	0100	00100	00	11	-0.270
460800	0100	00001	00	22	-0.270
921600	0100	00001	00	11	-0.270
1843200	0100	00100	00	02	-0.270
3686400	0100	00100	00	01	-0.270



Warning: The baud rates higher than 115,200 bps are not guaranteed to work.

6.5 Customized Baud Rate

■ To generate baud rate 125,000 bps:

$$125,000 * 16 * 8 = 16,000,000 = 16 \text{ MHz crystal}$$

So, when you use a 16 MHz crystal to replace the built-in 14.7 MHz crystal (for U versions VXC cards) and select the baud rate 115,200 bps in your software setting, the hardware will generate baud rate 125 kbps actually.



Note: External 14.7 MHz crystal can be customized to replace (for U versions VXC cards), but VEX cards (PCI Express) can't.

■ To generate baud rate 250,000 bps:

$$250,000 * 16 * 4 = 16,000,000 = 16 \text{ MHz crystal}$$

(Baud rate * 16 x clock * Divisor = Crystal Clock Frequency)

Thus, when you use a 16 MHz crystal to replace the built-in 14.7 MHz crystal (for U versions VXC cards) and select the baud rate 230,400 bps in your software setting, the hardware will generate baud rate 250 kbps actually.



Note:

The multi-port serial cards can have a special baud rate in OEM version. Please contact us for more information regarding the OEM products.



Warning:

The baud rates higher than 115,200 bps are not guaranteed to work.